

Review Article

Multiscale Modeling and Mathematical Problems Related to Tumor Evolution and Medical Therapy*

NICOLA BELLOMO[†], ELENA DE ANGELIS[‡] and LUIGI PREZIOSI[§]

Department of Mathematics, Politecnico, Torino, Italy

(Received 22 January 2004; In final form 22 January 2004)

This paper provides a survey of mathematical models and methods dealing with the analysis and simulation of tumor dynamics in competition with the immune system. The characteristic scales of the phenomena are identified and the mathematical literature on models and problems developed on each scale is reviewed and critically analyzed. Moreover, this paper deals with the modeling and optimization of therapeutical actions. The aim of the critical analysis and review consists in providing the background framework towards the development of research perspectives in this promising new field of applied mathematics.

Keywords: Multiscale modeling; Tumor evolution; Medical therapy

INTRODUCTION

Cancer modeling is an highly challenging frontier of applied mathematics. It refers to complex phenomena that appear at different scales: originally the cellular scale and eventually the macroscopic scale corresponding to condensation of cancer cells into solid forms interacting with the outer environment. The interest of applied mathematicians is documented in a large number of papers published in journals of applied mathematics or specifically devoted to the interactions between mathematics and biological and medical sciences. Some of these papers will be reviewed and critically analyzed in the sections which follow.

A large bibliography can already be recovered in two books edited by Adam and Bellomo (1996), and by Preziosi (2003). The contents of the chapters of these books clearly show how in a very short time, less than a decade, a great deal of improvements of mathematical modeling and methods have been developed. In the same period, the interaction between mathematics and medicine appears to have quantitatively and qualitatively improved going from an intellectual aim to an effective interaction and collaboration. Indeed, a great deal of novelty can be

discovered in the second book with respect to the state of the art reported in the first one. Analogous remarks can be applied to special issues of scientific journals edited by Chaplain (2002), and by Bellomo and De Angelis (2003).

Anticipating the contents of the next sections, some specific topics can be extracted from the contents of the above books and issues. Specifically,

- Cancer phenomena appear at different scales from the subcellular to the macroscopic one. Mathematical models are required to deal with this aspect bearing in mind that even when most of the phenomena appear at the macroscopic scale, cellular events play a concomitant and relevant role. Conversely, when the relevant aspect of the evolution appear at the cellular scale, it is necessary to figure out how cellular dynamics can generate pattern formation which may be phenomenologically observed at the macroscopic scale.
- An interesting field of interaction between mathematics and biology refers to the modeling and optimization of specific therapies such as the activation of the immune system or the control of angiogenesis phenomena, i.e. the recruitment of new capillaries and blood vessels from pre-existing blood vessels.

*Dedicated to Carlo Carlo Cercignani on the occasion of his 65th birthday.

[†]Corresponding author. E-mail: nicola.bellomo@polito.it

[‡]E-mail: elena.deangelis@polito.it

[§]E-mail: luigi.preziosi@polito.it

The above topics, selected among several ones, will be the guiding lines of this paper which aims not only at providing a critical analysis of the existing literature, but also at indicating research perspectives toward a qualitative improvement of the mathematical models and methods describing cancer phenomena.

Motivations are undoubtedly relevant. Indeed, cancer is one of the greatest killers in the world particularly in western countries although medical activity has been successful at least for some pathologies thanks to a great effort of human and economical resources devoted to cancer research. Moreover, it is recognized that any successful development of medical treatment in cancer therapy may hopefully be exploited toward other types of pathology.

The scientific community is aware that the great revolution of this century will be the development of a mathematical theory of complex biological systems. This means dealing with phenomena related to the living matter, while the revolution of the past two centuries was essentially related to the inert matter. The following question can be naturally posed: can research activity in molecular biology and medicine possibly take advantage of a certain, however limited, interaction with mathematics?

Rather than discussing the above topics by personal ideas we report few sentences by scientists who have significantly contributed to the research activity in the field. The first ones are extracted from a paper by Gatenby and Maini (2003), where the above-mentioned involvement of mathematical sciences in cancer modeling are scientifically motivated and encouraged:

Existing mathematical models may not be entirely correct. But they represent the necessary next step beyond simple verbal reasoning and linear intuition. As in physics, understanding the complex, non-linear systems in cancer biology will require ongoing interdisciplinary, interactive research in which mathematical models, informed by extant data and continuously revised by new information, guide experimental design and interpretation.

Then, going on with technical details:

These models might, for example, adapt methods of game theory and population biology to frame the “Vogelgram” mathematically as a sequence of competing populations that are subject to random mutations while seeking optimal proliferative strategies in a changing adaptive landscape. The phenotypic expression of each mutation interacts with specific environmental selection factors that confer a proliferative advantage or disadvantage. Such models will generate far less predictable (and more biologically realistic) system behavior, including multiple possible genetic pathways and timelines in the somatic evolution of invasive cancer.

Still in the same line, the following sentence from the paper by Greller *et al.* (1996) is worth recalling:

To the degree that a model is an adequate representation of biological reality, it can be used to perform “experiments” that are impossible or impractical in the laboratory. The danger of discovering phenomena that are artifacts of the model must be always scrutinized, but the properties of a model may also foretell genuine biological situations that are yet to be observed.

In addition to the above motivations, an additional one may be stated from the viewpoint of applied mathematicians: the application of mathematical models

in immunology and cancer modeling not only generates interesting and challenging mathematical problems, but effectively motivates the development of new mathematical methods and theories. Indeed, applied mathematicians have to look for new paradigms, which may generate new classes of equations to be dealt with by sophisticated analytic and computational methods.

This paper deals with the above topics with the aim to develop a review and a critical analysis of the state-of-the-art on the modeling of tumor evolution contrasted by the immune system and the therapeutical actions. The above review will then be addressed to propose new ideas and research perspectives in this fascinating new area of applied mathematics.

The content is proposed through six sections. The first part deals with modeling. In detail, the second section, which follows the above introduction, provides a phenomenological description of the system we are dealing with. The description, somehow naive, retains some aspects of the way of thinking of an applied mathematician, who always has in mind the need for transferring the phenomenological observation into equations. Certainly, biologists may be disappointed by it, considering that their attitude generally entails a deep look at certain phenomena without an immediate aim to transfer this observation into mathematical equations. In this case, the phenomenological description may be very detailed. On the other hand, the mathematical description can hopefully put in evidence behaviors that are not, or even cannot, be observed. In detail, this section provides a description of the phenomenology of the system with special attention to the different scales characterizing the system, from the subcellular scale to the macroscopic behavior, thus assessing the general framework for mathematical modeling.

The third and fourth sections deal with the mathematical modeling of the above system referred to two representation scales: the cellular one (at a statistical level) and the macroscopic one which can be exploited to model the evolution of tumors condensed into solid forms. Specifically, the third section deals with a review of mathematical models developed at a cellular scale and based on a mean field description, corresponding to the Vlasov equation. Models describe statistically the behavior of the system with particular attention to the competition between tumor and immune cells. This type of modeling retains certain aspects of phenomena developed at the subcellular scale. This means modeling cell activity and signaling in relation with loss of differentiation and interactions between tumor cells and the immune system. The fourth section deals with modeling macroscopic phenomena by non-linear partial differential equations and free boundary problems, thus describing the interactions of solid tumors with the outer environment. Also, we shall see that the derivation of macroscopic models retains the need for the modeling of phenomena developed at the cellular scale.

The second part deals with research perspectives. Specifically, the fifth section is dedicated to modeling and analysis of two therapeutical actions, the activation of the immune system and the control of angiogenesis phenomena, bearing in mind the problem of drug delivery. The above topics are related to the class of models, cellular and macroscopic ones, described in the fourth section. Certainly, additional therapies can be the object of modeling. On the other hand, focusing only on the above actions allows a deeper methodological analysis of this matter which only recently became the subject of a systematic research activity by applied mathematicians.

Finally, the last section looks at research perspectives and methodological aspects, in particular in relation with the interactions between mathematics and sciences of molecular biology and medicine. The authors of this paper support the idea that this interaction may not only be useful, but can also provide reciprocal relevant hints to new research frontiers within the above scientific environment. Then starting from the above analysis, some research perspectives are offered for the reader's attention.

PHENOMENOLOGY AND SCALING

Cancer is a complex multistage process. As described by various authors (Adam, 1996; Preziosi Ed., 2003), it is a consequent breakdown of the normal cellular interaction and control of replication. The sequential steps of the evolution of the system may be roughly summarized as follows:

1. Genetic changes, distortion in the cell cycle and loss of apoptosis.
2. Interaction and competition at the cellular level with immune and environmental cells. This stage includes activation and inhibition of the immune system. This action is also developed through cytokine signal emission and reception which regulate cell activities.
3. Condensation of tumor cells into solid forms, macroscopic diffusion and angiogenesis.
4. Detachment of metastases and invasion.

The first two steps are mainly related to cellular phenomena; the last two need macroscopic descriptions although cellular phenomena cannot be neglected as they are always the entities generating the macroscopic behavior.

The steps listed above clearly show how the process of tumor evolution involves many different phenomena which occur at different scales. Specifically, it is possible to distinguish three main scales as the natural ones characterizing the phenomenon: the subcellular, the cellular and the macroscopic scale. The system shows interesting phenomena on each single scale. A theory should retain all relevant features from the lower to the higher scale.

From the point of view of the mathematical modeling, this means that the problem requires different approaches,

because mathematical models related to cellular phenomena are generally stated in terms of ordinary differential equations and deal with the behavior of a single cell, while integro-differential kinetic equations are used for collective phenomena. On the other hand, macroscopic behaviors are generally described by non-linear partial differential equations that should lead to mathematical problems stated as moving boundary problems. The development of control activities can be organized along each of the steps above.

To begin with, we limit the description to some and hopefully most relevant phenomena occurring at each scale, artificially separating them on the basis of the scale involved.

The *subcellular scale* refers to the main activities within the cells or at the cell membrane. Among an enormous number of phenomena one can focus on

- (i) Aberrant activation of signal transduction pathways that control cell growth and survival;
- (ii) Genetic changes, distortion in the cell cycle and loss of apoptosis;
- (iii) Response of the cellular activity to the signals received;
- (iv) Absorption of vital nutrients.

A large amount of literature related to the above features can be found. Several interesting papers are cited in the review paper by Lustig and Behrens (2003), focusing on the dependence of cancer development on the aberrant activation of signal pathways that control cell growth and survival.

The *cellular scale* refers to the main (interactive) activities of the cells: activation and proliferation of tumor cells and competition with immune cells. More specifically, one has

- (i) Fast proliferation of tumor cells, which are often degenerated endothelial cells, takes place when an environmental cell loses its death program and/or starts undergoing mitosis without control.
- (ii) Competition with the immune system starts when tumor cells are recognized by immune cells, resulting either in the destruction of tumor cells or in the inhibition and depression of the immune system.
- (iii) After differentiation tumor cells undergo a process of maturation, which makes them more and more proliferative and aggressive toward the environment and the immune system. Tumor cells can be additionally activated towards proliferation by nutrient supply from the environment.
- (iv) Activation and inhibition of the immune cells in their competition with tumor cells are regulated by cytokine signals. These interactions, developed at the cellular level, are ruled by processes which are performed at the subcellular scale.
- (v) Activation and inhibition of cells belonging to the tumor and to the immune system can also be induced by a properly addressed medical treatment.

A model developed at the microscopic scale defines the time evolution of the physical state of a single cell. Often these models are stated in terms of ordinary differential equations. On the other hand, if we aim to describe the evolution of a system comprising a large number of cells, then the system of ordinary differential equations (one for each cell) can be replaced by a kinetic equation on the statistical distribution of the state of all cells. The application of methods of mathematical kinetic theory to model the competition between tumor and immune cells was initiated by Bellomo and Forni (1994), and developed in a sequel of papers as it will be reviewed in the “Modeling by generalized kinetic cellular theory” section.

The *macroscopic scale* refers to phenomena which are typical of continuum systems: cell migration, convection, diffusion (of chemical factors, nutrients), phase transition (from free to bound cells and vice versa) detachment of cells and formation of metastases, and so on. After a suitable maturation time, tumor cells start to condense and aggregate into a quasi-spherical nucleus and interact with the outer environment.

In this stage three overlapping phases of growth are usually identified: the avascular phase, the angiogenic phase and the vascular phase.

In particular, the *avascular stage of growth* is characterized by:

- (i) Small and occult lesions (1–2 mm in diameter);
- (ii) Formation of a necrotic core of dead tumor cells where a process of destroying cellular debris may take place;
- (iii) Formation of an outer region of proliferating tumor cells and of an intermediate region of quiescent cells;
- (iv) Production of chemical factors, among which several growth inhibitory factors, generally called GIF, and growth promoting factors, called GPF, by the tumor mass, thus controlling the mitosis;
- (v) Dependence of the tumor cells mitotic rate on the GIF and GPF concentration;
- (vi) Non-uniformities in the proliferation of cells and in the consumption of nutrients, which filter through the surface of the spheroid and diffuse in the intracellular space.

As at this stage the tumor is not surrounded yet by capillaries, this phase can be observed and studied in laboratory by culturing cancer cells.

On the other hand, the *tumor angiogenic phase* is characterized by:

- (i) Secretion of tumor angiogenesis factors promoting the formation of new blood vessels (VEGF, FGF and others) as described in Bussolino *et al.* (2003);
- (ii) Degradation of basement membrane by several enzymes. Endothelial cells are then free to proliferate and migrate towards the source of the angiogenic stimulus;

- (iii) Recruitment of new blood vessel that supply the tumor (neovascularization) and increase of tumor progression;

- (iv) Aberrant vascular structure, abnormal blood flow, with continuous growth of new tumor blood vessels.

A macroscopic description of the system should focus on these features and aim at giving their evolution in time. Obviously, the macroscopic behavior depends on phenomena occurring at the cellular level, e.g. proliferation, death, activation and inhibition of single cells, interaction between pairs of cells, etc.

The evolution of macroscopic observables can be described by models developed in the framework of continuum phenomenologic theories, e.g. those of continuum mechanics. These models are generally stated in terms of partial differential equations.

The link between the microscopic and the macroscopic description is one of the main open problems that we shall see in “On the interactions between mathematics and biology and perspectives” section, for scientists involved in the research field we are dealing with.

MODELING BY GENERALIZED KINETIC CELLULAR THEORY

During the first stages of evolution tumor cells have not yet condensed into a solid form. They have just differentiated from the other endothelial cells and, if recognized by the immune system, are attacked. This interaction and competition may end up either with the control of tumor growth or with the inhibition of the immune system, and hence with the growth and condensation of the tumor into a solid form. In this scheme, each cell can be characterized by one or more biological activities, which are supposed to represent the relevant activities of the cells in the collective phenomena.

The evolution related to the above collective behavior can be described by the so-called generalized kinetic theory which provides a statistical description of the evolution of large populations of cells undergoing kinetic type interactions. The results of these interactions depend on the activation state of the cells, and may modify the activation state of the interacting cells and/or generate proliferation/destruction phenomena.

The above mathematical approach was first proposed by Bellomo and Forni (1994) and then developed by various authors, e.g. Bellomo *et al.* (1999), De Angelis and Mesin (2001), Ambrosi *et al.* (2002), Arlotti *et al.* (2002a), De Angelis and Jabin (2003), Kolev (2003) and Bellouquid and Delitala (2004). Additional bibliography can be recovered in the review papers by Bellomo and De Angelis (1998) and, more recently by Bellomo *et al.* (2003a). Mathematical aspects related to the derivation and qualitative analysis of the above models can be recovered in Arlotti *et al.* (2002b; 2003). Additional

studies are in progress as documented in Bellomo *et al.* (2004).

The substantial difference with respect to the equations of the kinetic theory is that the microscopic state of the cells is defined not only by mechanical variables, say position and velocity, but also by an internal biological microscopic state related to the typical activities of the cells of a certain population.

This section deals with the above theory bearing in mind the modeling of therapeutical actions within a multiscale framework. The line to be followed in the modeling process is indicated below:

1. Selection of the cell populations which play the game and their biological activities;
2. Modeling microscopic interactions and derivation of the evolution equations;
3. Application of the model to describe phenomena of interest for molecular biology;
4. Derivation of a general framework for modeling large systems of cell populations.

The contents of this section follow the above index and is then organized into four subsections which report about the existing literature. As we shall see, some interesting problems have been solved, while a broad variety of problems are still open.

The development of each one of the above steps needs an effective ability to reduce the high complexity of the system we are dealing with. Specifically, the selection of the cell populations that play the game has to be interpreted as the selection of those who may play a role relatively more relevant than others. The same reasoning may be applied to the selection of the biological activities.

Moreover, modeling cellular microscopic interactions means developing a game theory with stochastic interactions. Indeed, the reduction of the complexity of the system implies that determinism is lost, replaced by stochastic games.

It is worth stressing, with reference to the existing literature, that two different classes of models have been proposed on the basis of two different ways of modeling microscopic interactions. The first class, which essentially refers to the pioneer work by Bellomo and Forni (1994), is developed with the assumption of localized interactions: pairs of cells interact when they get in contact. The second class, proposed by De Angelis and Mesin (2001), is developed with the assumption of mean field interactions: field cells interact with all cells within their action domain.

The review which follows essentially refers to this second class of models. Indeed, as analyzed by Bellomo *et al.* (2004), this type of model appears to be relatively more flexible to describe space dynamics. Bearing this in mind, the contents, which follow, will essentially refer to the spatially homogeneous case. Indeed models, useful for the applications, are available only in this relatively simpler case. Nevertheless, some indications on space

dependent models will be given having in mind multiscale modeling problems.

The above index shows that the review refers to a specific model with the aim of avoiding abstract formalizations. On the other hand, general methodological aspects are dealt with in the last subsection essentially looking at research perspectives.

Cell Populations

The immune competition involves several interacting populations each one characterized by a microscopic internal state which may differ from one population to the other. In fact, the dynamics involves at least cells of the immune system and cells of the aggressive host in the presence of environmental cells.

An interesting class of models was developed after De Angelis and Mesin (2001) selecting three interacting populations: cancer cells, immune cells and environmental cells.

As already mentioned, the above selection has to be regarded as a way to reduce complexity, however, pursuing the objective of designing models suitable to provide a detailed description of some interesting biological phenomena. Referring to the three populations indicated above the modeling of the biological activity can be developed assuming that the microscopic state is a scalar $u \in [0, \infty)$ and has a different meaning for each population: progression for tumor cells, defense ability for immune cells and feeding ability for environmental cells.

The model, obtained by methods of the mathematical kinetic theory, refers to evolution of the distribution functions $f_i = f_i(t, u)$ over the microscopic state u , where $i = 1$ refers to tumor cells, $i = 2$ to immune cells and $i = 3$ to environmental cells.

Modeling Microscopic Interactions and Evolution Equations

Consider the interactions between a test cell and a field cell which are homogeneously distributed in space within a certain control volume. Interactions may change the state of the cells and generate birth and death processes. The modeling is based on the following assumptions:

- The action of the field cells with state w belonging to the k -th population on the test cells of the i -th population with state u is modeled by the superposition of two different actions: a conservative action which modifies the state of the particles, but not their number; and a non-conservative action which generates a birth or death process in the states of the interacting pair.
- Conservative actions are modeled by the function

$$\varphi_{ik} = \varphi_{ik}(u, w), \quad (1)$$

such that its resultant action is

$$\mathcal{F}_i[\mathbf{f}](t, u) = \frac{\partial}{\partial u} \left[f_i(t, u) \sum_{k=1}^3 \int_0^{\infty} \varphi_{ik}(u, w) f_k(t, w) dw \right]. \quad (2)$$

- Non-conservative actions are modeled by the function

$$\psi_{ik}(v, w) \delta(v - u), \quad (3)$$

such that its resultant action is

$$\sigma_i[\mathbf{f}](t, u) = f_i(t, u) \sum_{k=1}^3 \int_0^{\infty} \psi_{ik}(u, w) f_k(t, w) dw. \quad (4)$$

- A source term can be added to model the inlet from the outer environment into the control volume.

The balance scheme which generates the model is reported in Fig. 1. Accordingly, the resultant structure of the evolution model, in the absence of inlet from the outer environment, is the following:

$$\begin{aligned} \frac{\partial}{\partial t} f_i(t, u) + \frac{\partial}{\partial u} \left[f_i(t, u) \sum_{k=1}^3 \int_0^{\infty} \varphi_{ik}(u, w) f_k(t, w) dw \right] \\ = f_i(t, u) \sum_{k=1}^3 \int_0^{\infty} \psi_{ik}(u, w) f_k(t, w) dw. \end{aligned} \quad (5)$$

Of course, specific models are obtained, as we shall see, by specializing the microscopic interactions.

Application

The mathematical structure described in the ‘‘Modeling microscopic interactions and evolution equations’’ section can be exploited to derive specific models based on a detailed description of microscopic interactions. A specific model can be obtained by the following assumptions:

- The progression of neoplastic cells is not modified by interactions with other cells of the same type, while it is weakened by interaction with immune cells (linearly depending on their activation state); and it is increased by interactions with environmental cells (linearly depending on their feeding ability).

The effect increases with increasing values of the progression:

$$\varphi_{11} = 0, \quad \varphi_{12} = -\alpha_{12}wu, \quad \varphi_{13} = \alpha_{13}wu. \quad (6)$$

- The defense ability of immune cells is not modified by interactions with other cells of the same type and with environmental cells, while it is weakened by interaction with tumor cells (linearly depending on their activation state) due to their ability to inhibit the immune system:

$$\varphi_{21} = -\alpha_{21}wu, \quad \varphi_{22} = \varphi_{23} = 0. \quad (7)$$

- The feeding ability of environmental cells is not modified by interactions with other cells of the same type and with immune cells. On the other hand, it is weakened by interaction with tumor cells linearly depending on their activation state:

$$\varphi_{31} = -\alpha_{31}wu, \quad \varphi_{32} = \varphi_{33} = 0. \quad (8)$$

- No proliferation of neoplastic cells occurs due to interactions with other cells of the same type. On the other hand, interactions with immune cells generate a destruction linearly depending on their activation state; and a proliferation by interactions with environmental cells depending on their feeding ability and the progression of tumor cells:

$$\psi_{11} = 0, \quad \psi_{12} = -\beta_{12}w, \quad \psi_{13} = \beta_{13}uw. \quad (9)$$

- No proliferation of immune cells occurs due to interactions with other cells of the same type and with environmental cells. On the other hand, interactions with tumor cells generate a proliferation linearly depending on their defense ability and on the activation state of tumor cells:

$$\psi_{21} = \beta_{21}uw, \quad \psi_{22} = \psi_{23} = 0. \quad (10)$$

- No proliferation of environmental cells occurs due to interactions with other cells of the same type and with immune cells. On the other hand, interactions with tumor cells generate a destruction linearly depending on the activation state of tumor cells:

$$\psi_{31} = -\beta_{31}w, \quad \psi_{32} = \psi_{33} = 0. \quad (11)$$

The derivation of the evolution equation is based on the above model of cell interactions as well as on

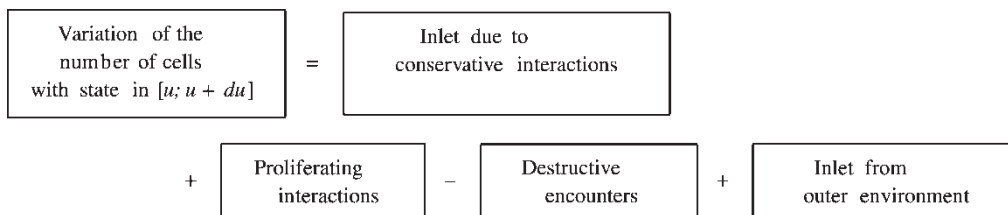

FIGURE 1 Scheme of the balance equations.

the methodological approach described in the preceding subsection. Technical calculations yield

$$\begin{aligned} \frac{\partial f_1}{\partial t} &= \frac{\partial}{\partial u} [\alpha_{12} u f_1(t, u) A[f_2](t) - \alpha_{13} u f_1(t, u) A[f_3](t)] \\ &\quad + \beta_{13} u f_1(t, u) A[f_3](t) - \beta_{12} f_1(t, u) A[f_2](t), \\ \frac{\partial f_2}{\partial t} &= \frac{\partial}{\partial u} [\alpha_{21} u f_2(t, u) A[f_1](t)] + \beta_{21} u f_2(t, u) A[f_1](t), \\ \frac{\partial f_3}{\partial t} &= \frac{\partial}{\partial u} [\alpha_{31} u f_3(t, u) A[f_1](t)] - \beta_{31} f_3(t, u) A[f_1](t), \end{aligned} \quad (12)$$

where the operator $A[\cdot]$ is defined as follows:

$$A[f_i] = \int_0^{+\infty} w f_i(t, w) dw. \quad (13)$$

The above model is characterized by eight parameters which have to be regarded as positive, small with respect to 1, constants, to be identified by suitable experiments as documented by Bellouquid and Delitala (2004) for a model with localized interactions.

Specifically, the α -parameters correspond to conservative encounters:

- α_{12} refers to the weakening of progression of neoplastic cells due to encounters with active immune cells;
- α_{13} refers to the increase of progression of neoplastic cells due to encounters with endothelial cells;
- α_{21} is the parameter corresponding to the ability of tumor cells to inhibit the active immune cells;
- α_{31} refers to the weakening of the feeding ability of endothelial cells due to encounters with neoplastic cells.

The β -parameters refer to proliferative and destructive interactions. Specifically:

- β_{12} refers to the ability of immune cells to destroy tumor cells;
- β_{13} corresponds to the proliferation rate of tumor cells due to their encounters with endothelial cells;
- β_{21} is the parameter corresponding to the proliferation rate of immune cells due to their interaction with tumor cells;
- β_{31} is the parameter corresponding to the destruction rate of endothelial cells due to their interaction with tumor cells.

The above system corresponds to the case of a closed system where the number of environmental cells decay in time due to their death due to feeding of tumor cells. One may possibly model an open system, where their number and activity is constant in time due to inlet of new cells from the outer environment. This means

$$f_3(u) = f_{30}(u), \quad A[f_3] = A_{30} = C.st;$$

then the system can be rewritten in the following relatively simpler form:

$$\begin{aligned} \frac{\partial f_1}{\partial t} &= \frac{\partial}{\partial u} [\alpha_{12} u f_1(t, u) A[f_2](t) - \alpha_{13}^* u f_1(t, u)] \\ &\quad + \beta_{13}^* u f_1(t, u) - \beta_{12} f_1(t, u) A[f_2](t), \\ \frac{\partial f_2}{\partial t} &= \frac{\partial}{\partial u} [\alpha_{21} u f_2(t, u) A[f_1](t)] + \beta_{21} u f_2(t, u) A[f_1](t), \end{aligned} \quad (14)$$

where $\alpha_{13}^* = \alpha_{13} A_{30}$, $\beta_{13}^* = \beta_{13} A_{30}$. Model (14) is then characterized by six parameters.

A qualitative analysis of the solutions to the initial value problem related to above model (12) was studied by De Angelis and Jabin (2003), while a computational analysis was developed by De Angelis *et al.* (2003). Both papers show that the α -parameters play an important role on the qualitative behavior of the asymptotic, in time, solutions. Particularly important is the role of the parameters α_{21} corresponding to the ability of tumor cells to inhibit the active immune cells, and of α_{31} which refers to the weakening of the feeding ability of endothelial cells due to encounters with neoplastic cells. Indeed, there exist critical values which separate two different behaviors:

- blow up of tumor cells corresponding to feeding ability of endothelial cells and/or inhibition of immune cells;
- progressive destruction of tumor cells corresponding to limitations of the feeding ability of endothelial cells and/or activation of immune cells.

Before showing some simulations with special attention to the above phenomena, it is worth discussing the final objective of modeling this type of physical system and of developing a qualitative and computational analysis within the framework of the interactions between mathematics and medicine.

As we have seen, the above model is characterized by a certain number of parameters which can be divided into two groups, while all of them are related to specific biological activities. The main objective of the simulation involves showing which type of biological activity is crucial to modify the output of the competition between tumor cells and the immune system. This does not solve the specific problem of modifying, toward the desired direction, the biological activity. However, it may address medical research to specific directions to be developed with therapeutical purposes.

Bearing all this in mind, consider simulations with fixed values of β -type parameters developed for the open system (12). Simulations are reported in Figs. 2–5, which analyze the sensitivity of the solutions, with special attention to the asymptotic behavior, to the parameter α_{21} which corresponds to the ability of progressed cells to inhibit the immune system. Figure 2 shows how the evolution has a trend to increase the progression of tumor

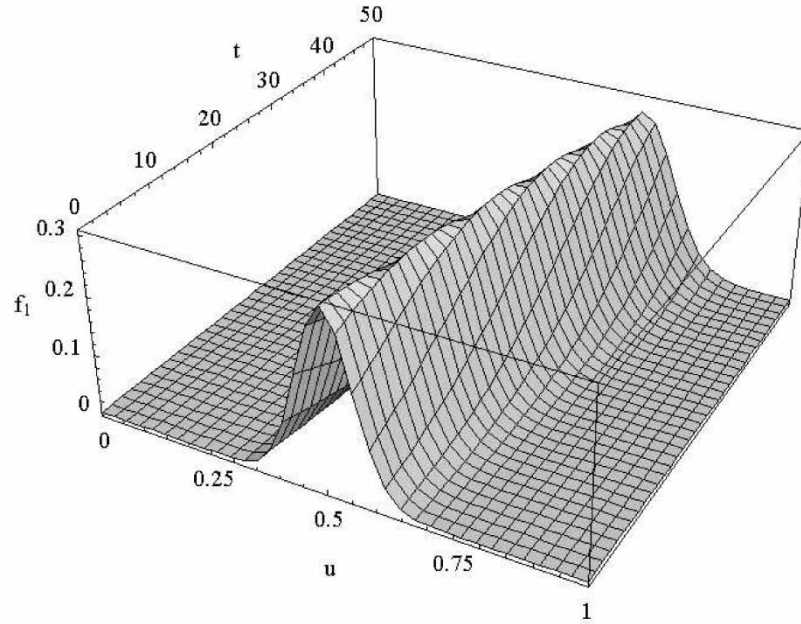

FIGURE 2 Evolution of tumor progression $\alpha_{21} > \alpha_{21}^c$.

cells by increasing the number and mean value of the progression. This behavior occurs when α_{21} is larger than a critical value α_{21}^c . In this case, the immune system is not able to contrast the neoplastic growth; tumor cells are able to increase their aggressiveness and to inhibit immune cells. The distribution function of the tumor cells evolves toward larger values of the state u , while the distribution of the immune cells is shifting toward lower values of u .

On the other hand the opposite behavior is observed when α_{21} is lower than α_{21}^c . This type of evolution is

observed in Fig. 4, where the number of progressed cells, and their activation, shows a trend to increase. Now the immune system is not able to control the growth of tumor cells as shown in the figure.

The evolution of the activation of immune cells corresponding to the above two types of evolution is shown in Figs. 3 and 5, respectively.

From the above simulations, the crucial role of the parameter α_{21} among the other parameters is clear. Indeed, α_{21} selects the asymptotic behavior of the system.

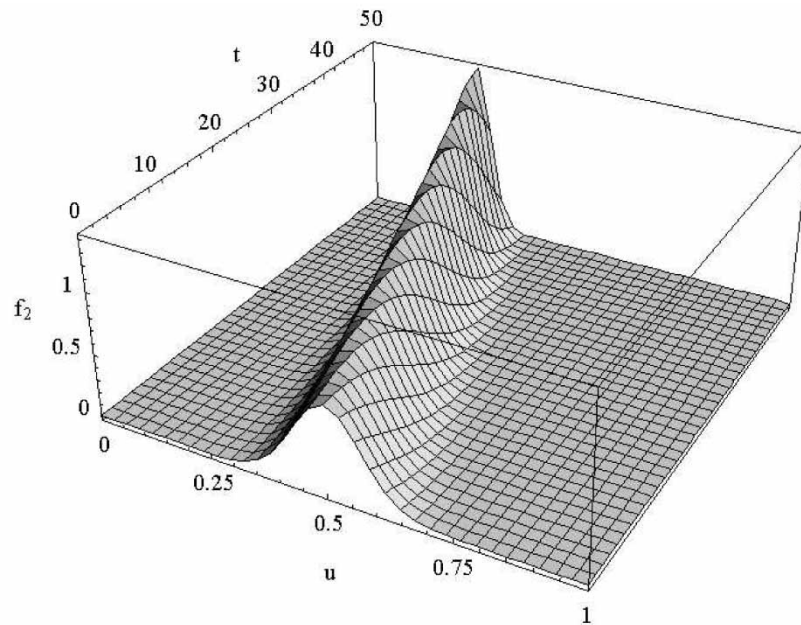

FIGURE 3 Evolution of immune cell activation for $\alpha_{21} > \alpha_{21}^c$.

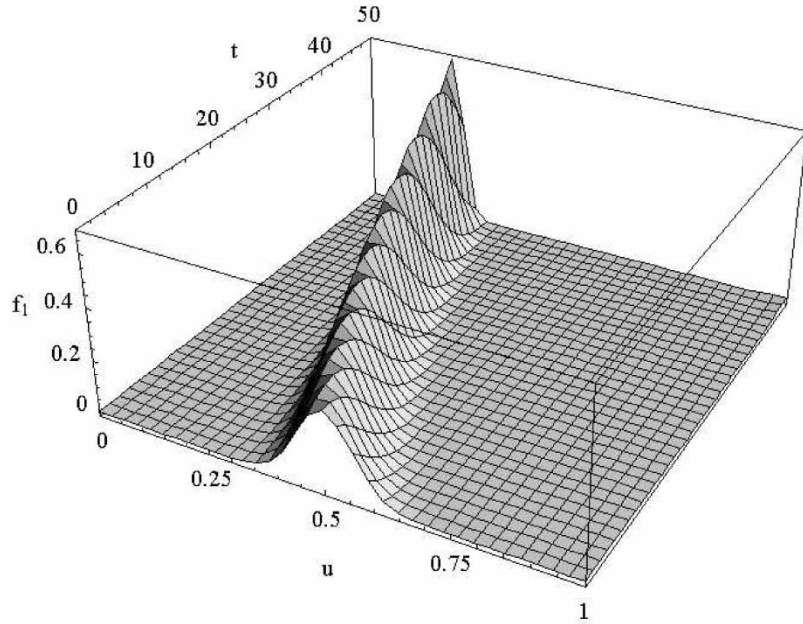

FIGURE 4 Evolution of tumor progression $\alpha_{21} < \alpha_{21}^c$.

Medical therapies can be focused to modify the effective action related to the above parameter.

Mathematical Models with Space Structure

The mathematical model described in the “Modeling microscopic interactions and evolution equations” section was developed in the spatially homogeneous case. On the other hand, various motivations have been given to support the need of models with space structure. This subsection provides a concise description, with reference to the paper by Bellomo *et al.* (2004) of

the mathematical framework which generates models of this type.

Models with space structure are such that the microscopic state of cells is defined by the vector variable which includes both mechanical and biological microscopic states:

$$\mathbf{w} = \{\mathbf{x}, \mathbf{v}, \mathbf{u}\} \in \mathcal{D} = D_{\mathbf{x}} \times D_{\mathbf{v}} \times D_{\mathbf{u}}, \quad (15)$$

where the position $\mathbf{x} \in D_{\mathbf{x}}$ and the velocity $\mathbf{v} \in D_{\mathbf{v}}$ are the microscopic mechanical variables, and $\mathbf{u} \in D_{\mathbf{u}}$, as we have seen, is the microscopic internal biological state.

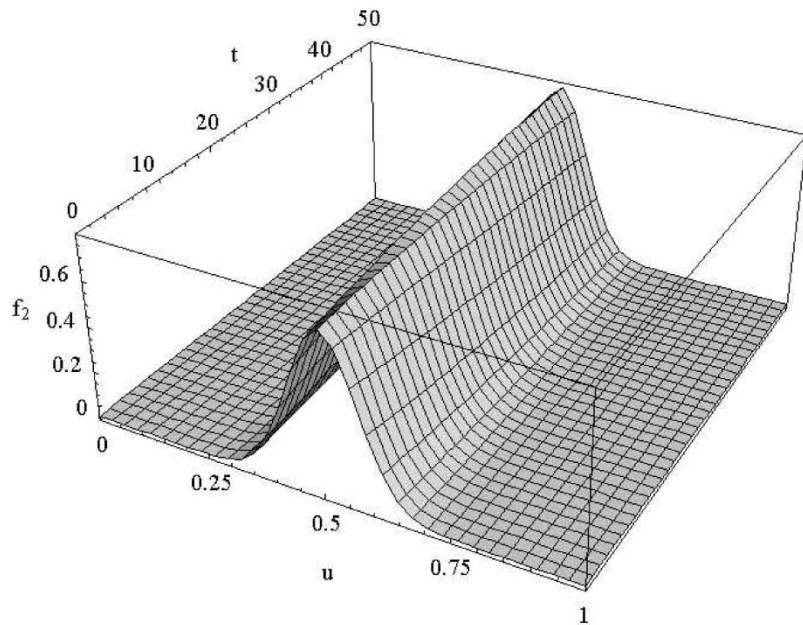

FIGURE 5 Evolution of immune cell activation for $\alpha_{21} < \alpha_{21}^c$.

A generalized kinetic model, for a system of several interacting populations each labeled with the subscript i , is an evolution equation for the distribution functions related to each cell population

$$f_i = f_i(t, \mathbf{w}) : \mathbb{R}_+ \times \mathcal{D} \rightarrow \mathbb{R}_+, \quad i = 1, 2, 3. \quad (16)$$

Macroscopic observable quantities can be recovered by suitable moments of the above distribution functions. For instance, the number density of cells or the size at time t and position \mathbf{x} is given, under suitable integrability properties, as follows:

$$n_i(t, \mathbf{x}) = \iint_{D_u \times D_v} f_i(t, \mathbf{x}, \mathbf{v}, \mathbf{u}) \, d\mathbf{v} \, d\mathbf{u}, \quad (17)$$

while the total number of cells at time t in a domain D_x is given by

$$N(t) = \sum_{i=1}^n \int_{D_x} n_i(t, \mathbf{x}) \, d\mathbf{x}. \quad (18)$$

The evolution equation, corresponding to mean field interactions, is derived supposing that it is possible to model the following two quantities:

- The action $\mathcal{P}_{ik} = \mathcal{P}_{ik}(\mathbf{w}, \mathbf{w}_*)$ on the test cell (of the i -th population) with microscopic state \mathbf{w} due to the field cell (of the i -th population) with \mathbf{w}_* , so that the resultant action is

$$\mathcal{F}_{ik}[f](t, \mathbf{w}) = \int_{\mathcal{D}} \mathcal{P}_{ik}(\mathbf{w}, \mathbf{w}_*) f_k(t, \mathbf{w}_*) \, d\mathbf{w}_*. \quad (19)$$

- The term describing proliferation and/or destruction phenomena in the state \mathbf{w} related to pair interactions between cells of the i -th population with microscopic state \mathbf{w}^* with cells of the k -th population with state \mathbf{w}^{**} is

$$\begin{aligned} \mathcal{S}_{ik}[f](t, \mathbf{w}) = & \int_{\mathcal{D}} \int_{\mathcal{D}} \sigma_{ik}(\mathbf{w}^*, \mathbf{w}^{**}; \mathbf{w}) f_i(t, \mathbf{w}^*) \\ & \times f_k(t, \mathbf{w}^{**}) \, d\mathbf{w}^* \, d\mathbf{w}^{**}, \end{aligned} \quad (20)$$

where σ_{ik} is a suitable proliferation–destruction function.

In this case, the derivation of the equation follows the same rules of the relatively simple case dealt with in the “Modeling microscopic interactions and evolution equations” section. Of course, the above approach only defines a mathematical framework for models that can be developed if the terms \mathcal{P}_{ik} and σ_{ik} are defined by specific models such as those we have seen in the “Application” section.

An additional difficulty is that the biological and mechanical functions generally show a reciprocal influence. This topic is not properly developed in

the existing literature, while only some methodological indications are given. Specifically, referring to mean field interactions, the paper by Bellomo *et al.* (2004) suggests the mechanical interactions by attractive and/or repulsive potentials selecting the action by the biological state.

Specific models have been proposed in the case of short interaction models. The analysis is addressed to a topic which is not dealt with in this paper: the derivation of macroscopic equations from the microscopic description (Hillen and Othmer, 2000; Hillen, 2002; Lachowicz, 2002; Bellomo and Bellouquid, 2004).

MACROSCOPIC MODELING

Proceeding in the evolution, tumor cells aggregate into a tumor mass which is made of several constituents (e.g. tumor cells, immune cells, environmental cells, extra-cellular matrix) with a growth which depends on several growth promoting and inhibitory factors, in addition to the nutrients. For modeling purposes it is useful to distinguish the components above into two classes:

1. the different types of cells, the extracellular matrix and the extracellular liquid permeating the tissue;
2. all the nutrients, macromolecules and chemical factors dissolved in the liquid, produced and absorbed by the cells.

The main reason for introducing this distinction is that while cells are bigger, occupy space, and are impenetrable, the relative dimension of chemical factors and nutrients can be neglected, they are produced and/or absorbed by the cells, and they diffuse through the tissue. The tumor can then be treated as a mixture of different constituents with chemical factors diffusing in the liquid phase.

In the following subsections, a class of model which takes into account the multicellular structure of a tumor will be described and it will be shown how classical models available in the literature can be obtained as particular cases.

Multicellular Models

The rough classification mentioned above means that the relevant state variables describing the evolution of entities like the cell populations, the extracellular matrix and the extracellular liquid are the volume ratios ϕ_j , $j = 1, \dots, P$ defined as the volume occupied by the j -th population over the total volume. The basis of this concept is that we are considering the continuum not in its real state (at the cellular level at any spatial point there can be only one constituent at a time), but as a mixture: at every point of the mixture there is a fraction ϕ_j of the j -th constituent (see Rajagopal and Tao, 1995 for a detailed description). On the other hand, the evolution of the chemical factors and nutrients can be described by their concentrations u_i , $i = 1, \dots, M$.

One can then write a system of mass balance equations for the cells, the extracellular matrix and the extracellular liquid

$$\rho \left[\frac{\partial \phi_j}{\partial t} + \nabla \cdot (\phi_j \mathbf{v}_j) \right] = \Gamma_j, \quad j = 1, \dots, P, \quad (21)$$

and a system of reaction–diffusion equations for the concentration of chemicals

$$\begin{aligned} & \frac{\partial u_i}{\partial t} + \nabla \cdot (u_i \mathbf{v}_\ell) \\ & = \nabla \cdot (Q_i \nabla u_i) + \tilde{G}_i - \tilde{D}_i u_i, \quad i = 1, \dots, M \end{aligned} \quad (22)$$

where Q_i is the diffusion coefficient of the i -th chemical factor, \mathbf{v}_j is the velocity of the j -th population, and, in particular, \mathbf{v}_ℓ is the velocity of the extracellular liquid. As in the reaction–advection–diffusion equation in the mass supply of the j -th constituent $\Gamma_j = \rho(G_j - D_j \phi_j)$. In Eq. (21), it has been assumed that all constituents have the same density ρ . The generalization to different densities is trivial.

Usually, the system of Eqs. (21) is associated with the assumption that the constituents identified fill the entire space, i.e.

$$\sum_{j=1}^P \phi_j = 1, \quad (23)$$

or a fixed portion of space

$$\sum_{j=1}^P \phi_j = \Phi. \quad (24)$$

This assumption is called saturation assumption. In this case, summing all Eqs. (21) one has

$$\rho \nabla \cdot \mathbf{v}_c = \sum_{j=1}^P \Gamma_j, \quad (25)$$

where

$$\mathbf{v}_c = \sum_{j=1}^P \phi_j \mathbf{v}_j, \quad (26)$$

is called composite velocity.

Probably, the most delicate point in dealing with the models (21) and (22) involves defining how cells move. This can be done either on the basis of phenomenological arguments, or writing momentum balance equations or force balance equation.

Most of the papers in the literature use the first approach, and operate under the assumption that the cells do not move, or that the motion is driven by chemotaxis, haptotaxis, or by an avoiding crowd dynamics, possibly including diffusive phenomena. In the following we will

use the second approach showing when the first approach can be obtained as a particular case. As we shall see this type of model has, for instance, the advantages of involving the forces exerted by the cells on the extracellular matrix and on the other tissues. It is then possible to study problems in which the mechanical interactions with the outer environment play a crucial role, e.g. tumor–tissue interactions, capillary collapse, fractures as in bone tumors and ductal carcinoma.

The starting point involves writing the momentum balance equations for the constituents

$$\begin{aligned} & \rho \phi_j \left(\frac{\partial \mathbf{v}_j}{\partial t} + \mathbf{v}_j \cdot \nabla \mathbf{v}_j \right) \\ & = \nabla \cdot \mathbf{T}_j + \phi_j \mathbf{f}_j + \mathbf{m}_j, \quad j = 1, \dots, P, \end{aligned} \quad (27)$$

where \mathbf{m}_j is the interaction force with the other constituents, \mathbf{T}_j is the partial stress tensor and \mathbf{f}_j is the body force acting on the j -th constituent, e.g. chemotaxis.

In many biological phenomena, inertial terms (or better persistence terms) on the left hand side of Eq. (27) can be neglected and the main contribution to the interaction forces can be assumed to be proportional to the velocity difference between the constituents

$$\mathbf{m}_j = \mathbf{m}_j^0 - \sum_{k=1, k \neq j}^P M_{jk} (\mathbf{v}_j - \mathbf{v}_k),$$

where the coefficients M_{jk} are related to the relative permeabilities and satisfy the following relations $M_{jk} = M_{kj} > 0$. One can then rewrite the momentum equations as

$$\begin{aligned} & \sum_{k=1, k \neq j}^P M_{jk} (\mathbf{v}_j - \mathbf{v}_k) \\ & = \nabla \cdot \mathbf{T}_j + \phi_j \mathbf{f}_j + \mathbf{m}_j^0, \quad j = 1, \dots, P. \end{aligned} \quad (28)$$

In Preziosi and Graziano (2003) it has been proved that the system (28) can be manipulated to obtain the velocity fields in term of the stresses and of the other terms. This information can be then used to simplify Eqs. (21) and (22).

It is clear that Eq. (28) requires the description of cell-to-cell mechanical interactions, e.g. relating the forces determining cell motion to the level of compression, because this is one of the main causes of motion. For instance, when a tumor cell undergoes mitosis, the new-born cell presses the cells nearby to make space for itself. This “pressure” generates a displacement of the neighboring cells to eventually reach a configuration in which each cell has all the space it needs. In particular, this leads to tumor growth.

It is also clear that a multiscale approach should be taken into account in dealing with the influence of stress on growth, because for instance the perception of stress by the single cells and the triggering of mitosis or apoptosis occurs at a subcellular scale.

The easiest constitutive equations for the stress consists in assuming that the ensembles of cells behave as elastic liquids

$$\mathbf{T}_j = -\Sigma_j \mathbf{I}, \quad (29)$$

where Σ_j is positive in compression. Of course, thinking of tumor masses as elastic fluids is reductive as they respond to shear, while ideal materials satisfying Eq. (29) cannot sustain shear. In fact, in using Eq. (29) in three-dimensional problems one has to be aware of the possible instabilities to shear. There is no problem in generalizing Eq. (29) including viscous effects as done in Ambrosi and Preziosi (2002), Franks and King (2003) and Byrne and Preziosi (2004), or in considering the tumor as a viscoelastic fluid of any type, while it is more delicate to give the tumor a solid-like structure.

In fact, in the former case one is still working in a Eulerian framework, where the mechanical behavior of the fluid-like material is ruled by functional relations between stresses and rate of strains (including their histories). Therefore, even in the presence of growth, there is no need to look back at the state of the material before growth and deformation, and to define the deformation with respect to a reference or a natural configuration.

This, instead, is necessary when one wants to give the tumor some solid-like properties and represents a big conceptual problem because a growing material does not possess a reference configuration in the classical sense. Consequently, there are problems in defining the natural configuration where the tumor would tend to grow in the absence of external forces.

Of course, this problem does not characterize tumor growth only, but is encountered in several other applications ranging from bio-mechanics (e.g. bone remediation, growth of tissues, tissue engineering) to material sciences (e.g. crystallization, polymerization). Many papers have been written in these fields without realizing or bypassing the issue, some also dealing with tumor growth. However, recently some papers, mainly in material sciences and also in biomechanics (Rodriguez *et al.*, 1994; Taber, 1995; Di Carlo and Quiligotti, 2002; Humphrey and Rajagopal, 2002), have analyzed the problem. In particular, Humphrey and Rajagopal (2002) introduced the concept of multiple natural configurations which has already been applied by Ambrosi and Mollica (2002; 2003), to tumor growth with very interesting and promising results. Ambrosi and Mollica (2004) deduced a model which compared well with the experiments by Helmlinger *et al.* (1997) in which the stress inhibits the growth of a multicell spheroid growing in a gel with controllable stiffness.

1D Problems for a Single Incompressible Constituent

In this and in the following sections we will simplify the model presented in the previous section to discuss well-known classes of models.

As discussed by Byrne (2003) and Chaplain and Anderson (2003), most of the classical papers on tumor growth worked under the following hypotheses:

- The tumor is formed only by one type of cells which keeps a constant volume ratio (or density) ϕ_T , e.g. the population occupies all the space as a bunch of rigid spheres in a close packing configuration;
- Its shape is spherically symmetric (in some cases computations are performed in the one-dimensional Cartesian case).

This reduces the number of space variables to one and the velocity vector to a scalar. Hence, there is no need to introduce any closure assumption or momentum equation. In fact, one can directly write the evolution equation (21) for the single cell population considered (i.e. tumor cells) as

$$\frac{1}{r^2} \frac{\partial}{\partial r} (r^2 v_T) = \frac{G_T(u_1, \dots, u_n)}{\phi_T} - D_T(u_1, \dots, u_n), \quad \text{with } \phi_T = \text{const.} \quad (30)$$

The quantities on the right hand side of Eq. (30) refer to the different chemical factors and nutrients influencing the evolution. Assuming no drift and constant diffusion coefficients Q_i , they satisfy

$$\frac{\partial u_i}{\partial t} = \frac{Q_i}{r^2} \frac{\partial}{\partial r} \left(r^2 \frac{\partial u_i}{\partial r} \right) + \tilde{G}_i(u_1, \dots, u_n) - \tilde{D}_i(u_1, \dots, u_n) u_i, \quad i = 1, \dots, M. \quad (31)$$

Once the generation and decay terms \tilde{G}_i , \tilde{D}_i in Eq. (31) are specified, which however is still a crucial and difficult step and one which must be done on the basis of phenomenological observations, the system of equations in Eq. (31), supplemented by proper initial and boundary conditions, can be solved. This information can be substituted back in Eq. (30) to determine how the tumor grows.

In fact, the border of the tumor $R(t)$ moves with the tumor cells lying at its surface, i.e. with velocity

$$\frac{dR}{dt}(t) = v_T(R(t)), \quad (32)$$

so that the mathematical problem writes as a free boundary problem.

As already stated in this case it is not necessary to specify anything else on the velocity, which is obtained integrating Eq. (30). In particular, it can be used to determine how the tumor grows. In fact, integrating Eq. (30) and evaluating it in $R(t)$ gives

$$\begin{aligned} R^2(t) \frac{dR}{dt}(t) &= \frac{1}{3} \frac{dR^3}{dt}(t) \\ &= \int_0^{R(t)} \left[\frac{1}{\phi_T} G_T(u_1(r,t), \dots, u_n(r,t)) - D_T(u_1(r,t), \dots, u_n(r,t)) \right] r^2 dr, \quad (33) \end{aligned}$$

which corresponds to a mass balance over the entire tumor volume $\mathcal{T}(t)$

$$\rho \phi_T \frac{d}{dt} \int_{\mathcal{T}(t)} dV = \int_{\mathcal{T}(t)} \Gamma_T dV, \quad (34)$$

where, of course, the integral on the left hand side is the volume of the tumor $4\pi R^3(t)/3$.

1D Problems for Constrained Mixtures

As already stated the tumor is not formed by a single type of cells. So there is the need to introduce more populations and then to describe how they move. Even if not explicitly stated several papers dealing with more cell populations work under the assumptions that all constituents move with the same velocity

$$v_j = v, \quad j = 1, \dots, P. \quad (35)$$

In the multiphase literature this is called a constrained mixture assumption and implies that there is no relative movement among the constituents. In order to relax it, one can assume that there is a given relation among the velocities

$$v_j = \alpha_j v, \quad j = 1, \dots, P \quad (36)$$

with $\alpha_j \in [0,1]$ given and not necessarily all equal to one. For instance, some of the constituents may be fixed (i.e. $\alpha_j = 0$) and the others may move with a common velocity v (i.e. $\alpha_j = 1$).

The constrained mixture assumption is very useful in one-dimensional problems when joined with the saturation assumption (23) or (24). In fact it allows one to write, e.g. in spherical coordinates,

$$\frac{\partial \phi_j}{\partial t} + \frac{1}{r^2} \frac{\partial}{\partial r} (r^2 \phi_j \alpha_j v) = \frac{\Gamma_j}{\rho}, \quad j = 1, \dots, P, \quad (37)$$

where Γ_j depends on all ϕ_j and u_i .

As before, summing all the equations one can rewrite Eq. (25) as

$$\frac{\partial}{\partial r} \left(r^2 v \sum_{j=1}^P \alpha_j \phi_j \right) = \frac{r^2}{\rho} \sum_{j=1}^P \Gamma_j, \quad (38)$$

which can be integrated to explicitly obtain the velocity

$$v = \frac{1}{\rho r^2 \sum_{j=1}^P \alpha_j \phi_j} \int_0^{R(t)} \sum_{j=1}^P \Gamma_j r^2 dr.$$

An example of this type of model is given in the works of Bertuzzi and Gandolfi (2000) and Bertuzzi *et al.* (2002; 2003), which are aimed at the description of the evolution of tumor cords and possibly of the response to an anti-cancer treatment. For instance, Bertuzzi *et al.* (2003) considered a system with two cell populations, viable and dead tumor cells, with volume ratios ϕ_T and ϕ_D ,

respectively, and two chemicals, oxygen and a drug, with concentrations u_N and u_C , respectively, and worked in cylindrical symmetry. Their model then becomes

$$\frac{\partial \phi_T}{\partial t} + \frac{1}{r} \frac{\partial}{\partial r} (r \phi_T v) = \gamma(u_N) \phi_T - [\delta(u_N, t) + \delta_C(u_C, u_N)] \phi_T,$$

$$\frac{\partial \phi_D}{\partial t} + \frac{1}{r} \frac{\partial}{\partial r} (r \phi_D v) = [\delta(u_N, t) + \delta_C(u_C, u_N)] \phi_T - \delta_D \phi_D,$$

$$0 = \nabla^2 u_N - f(u_N) \phi_T, \quad (39)$$

$$\frac{\partial u_C}{\partial t} = \frac{Q}{r} \frac{\partial}{\partial r} \left(r \frac{\partial u_C}{\partial r} \right) - \varphi(u_N, u_C) \phi_T - \lambda u_C,$$

where γ is the growth coefficient, which depends on the amount of nutrient, δ is the rate of apoptosis and δ_C is that related to drug injection, f and φ refer, respectively, to nutrient and drug absorption by viable cells, and λ refers to drug wash-out.

Linking the volume ratio with the saturation assumption (24), Eq. (39) is a system of 4 equations in 4 unknowns, which can be solved once the gain and loss terms are specified.

A similar approach is also used by Ward and King (1997; 1998; 1999; 2003). In particular, in the first paper Ward and King considered the evolution of living and dead cells, while in the second they added the necrotic material as a macromolecule produced by the dead cells. In the third paper they considered three ‘‘cell’’ populations (living cells, re-usable material deriving from cell death and waste products) and nutrient diffusion. Finally, in the last paper they added the effect of a generic drug.

One Constituent on a Rigid Substratum and Darcy’s-type Closure

We will now consider the simplest example involving force balance, showing how Darcy’s-type closure can be obtained as a particular case. Assume then that a single population of cells moves in a rigid substratum, e.g. the extracellular matrix. Neglecting the influence of water, it is possible to reduce the model (21), (28) to

$$\rho \left[\frac{\partial \phi_T}{\partial t} + \nabla \cdot (\phi_T \mathbf{v}_T) \right] = \Gamma_T, \quad (40)$$

and

$$\nabla \cdot \mathbf{T}_T + \phi_T \mathbf{f}_T - M_{T0}(\phi_T) \mathbf{v}_T = \mathbf{0}, \quad (41)$$

which still need to be joined with the reaction–diffusion equations (22) with $\mathbf{v}_\ell = \mathbf{0}$. It need to be observed that in Eq. (41) the drag force acting on the tumor cell population depends on the volume ratio, in the easiest case it is proportional to it.

Of course, the model above requires the specification of the constitutive equations for the stress. As already mentioned in the ‘‘Multicellular models’’ section, the easiest possibility is to model the ensemble of cells moving in the rigid extracellular matrix as an elastic fluid

$\mathbf{T}_T = -\Sigma(\phi_T)\mathbf{I}$, where Σ is positive in compression. One can then explicitly write

$$\mathbf{v}_T = -K(\nabla\Sigma - \phi_T\mathbf{f}_T), \quad (42)$$

where $K = 1/M_{T0}$.

If $\mathbf{f}_T = 0$ it is possible to recognize the closure which is used in several papers (see for instance, McElwain and Pettet, 1993; Byrne and Chaplain, 1996; Byrne and Chaplain, 1997; De Angelis and Preziosi, 2000) and named Darcy's law

$$\mathbf{v}_T = -K\nabla\Sigma. \quad (43)$$

In most of the papers mentioned above the term Σ is called pressure, but should not be confused with the pressure of the extracellular liquid (i.e. the interstitial pressure). It describes the isotropic response of the multicell spheroid to compression and tends to drive tumor cells towards the regions with lower stresses. For this reason, Gurtin and McCamy (1977) and Bertsch *et al.* (1985) called this behavior "avoiding crowd mechanism".

It is possible to perform a further step by substituting \mathbf{v}_T back in Eq. (40):

$$\frac{\partial\phi_T}{\partial t} + \nabla \cdot \left[\frac{\phi_T}{M_{T0}} (\nabla \cdot \mathbf{T}_T + \phi_T\mathbf{f}_T) \right] = \frac{\Gamma_T}{\rho}, \quad (44)$$

while using Eq. (42) yields

$$\frac{\partial\phi_T}{\partial t} = \nabla \cdot [K\phi_T(\nabla\Sigma - \phi_T\mathbf{f}_T)] + \frac{\Gamma_T}{\rho}. \quad (45)$$

It can be noticed that the proper boundary condition for Eqs. (40) and (41) or for Eq. (45) involves the stress on the tumor boundary which moves with velocity \mathbf{v}_T . Therefore, the model can be used for describing those phenomena in which it is important to consider the role of stress, the interfacing with external tissues, and so on.

This process can be generalized to more populations, as documented in De Angelis and Preziosi (2000) and Chaplain and Preziosi (2004). The latter proposes a model that explains how the smallest misperception of the level of stress and compression of the surrounding tissue may cause hyperplasia and dysplasia and eventually the complete replacement of the normal cell population and extracellular matrix with the abnormal ones. The former paper proposed a model to describe tumor growth from the avascular stage to the vascular one through the angiogenic process without distinguishing the different phases but letting their identification stem naturally from the evolution. The paper focused on the fact that the tumor mass is growing in an evolving environment. Messages are exchanged between the cells living inside and outside the tumors. Therefore, the environment reacts to the presence of the tumor and vice versa.

In this respect, some of the state variables more strictly referred to the evolution of the tumor are defined only

within the tumor, e.g. the tumor cell densities, others more strictly referred to the evolution of the environment are defined both inside and outside the tumor. For instance, chemical factors produced by the tumor, i.e. in $\mathcal{T}(t)$, can diffuse in the outer environment and in some cases, e.g. VEGF, their work is out there. On the other hand, capillaries initially exist only outside the tumor, i.e. in the outer environment, but because of angiogenesis they proliferate and can penetrate the tumor.

The model presented in this section is a development of that presented in De Angelis and Preziosi (2000), taking into account that VEGF generation is stimulated in hypoxia and it is uptaken by endothelial cells.

The free-boundary problem describing the evolution of viable and dead tumor cells (ϕ_T and ϕ_D), capillaries (ϕ_C), nutrients (u_N), and tumor angiogenic factors (u_A) becomes

$$\begin{aligned} \text{in } \mathcal{D}: \quad \frac{\partial u_A}{\partial t} &= k_A \nabla^2 u_A + \gamma_A (\tilde{u}_N \phi_T - u_N) + \phi_T \\ &\quad - [\delta_A + \delta'_A (\phi_C + \hat{\phi}_C)] u_A, \\ \frac{\partial \phi_C}{\partial t} + w_C \nabla \cdot (\phi_C \nabla u_A) &= k_C \nabla^2 \phi_C + \gamma_C u_A (\bar{\phi}_C - \phi_C) \\ &\quad + (\phi_C + \hat{\phi}_C) - \delta_C \phi_C, \end{aligned}$$

and

$$\begin{aligned} \text{in } \mathcal{T}(t): \quad \frac{\partial \phi_T}{\partial t} &= w_T \nabla \cdot (\phi_T \nabla \phi) + \frac{\gamma_T}{\varepsilon} H(u_N - \tilde{u}_N \phi_T) u_N \phi_T \\ &\quad - \delta_T H(\bar{u}_N \phi_T - u_N) \phi_T, \\ \frac{\partial \phi_D}{\partial t} &= w_D \nabla \cdot (\phi_D \nabla \phi) + \delta_T H(\bar{u}_N \phi_T - u_N) \phi_T - \delta_D \phi_D, \\ \frac{\partial u_N}{\partial t} &= \nabla \cdot [(k_E + k_N (\phi_C + \hat{\phi}_C)) \nabla u_N] - \delta_N \phi_T u_N, \end{aligned}$$

while the boundary and initial conditions are given as follows

$$\begin{aligned} \text{interface evolution: } \mathbf{n} \cdot \frac{d\mathbf{x}_T}{dt} &= -w_T \mathbf{n} \cdot \nabla \phi(\mathbf{x}_T), \\ \text{boundary conditions on } \partial\mathcal{T}(t): \quad \phi_T &= \bar{\phi} - \phi_C - \hat{\phi}_C, \\ \phi_D &= 0, \\ u_N &= \varepsilon + \beta(\phi_C + \hat{\phi}_C), \\ \text{boundary conditions on } \partial\mathcal{D}: \quad u_A &= \phi_C = 0, \\ \text{initial conditions in } \mathcal{T}(t=0): \quad \phi_T &= \bar{\phi}, \quad \phi_D = 0, \\ u_N &= \tilde{u}_N, \\ \text{initial conditions in } \mathcal{D}: \quad u_A &= \phi_C = 0, \end{aligned}$$

where

$$f_+ = \begin{cases} f & \text{if } f > 0; \\ 0 & \text{otherwise.} \end{cases}$$

is the positive part of f and H is the Heavyside fuction.

The dimensionless form of the free-boundary problem depends on the following dimensionless numbers

$$\delta_A^* = \frac{\delta'_A \bar{\phi}}{\gamma_T}, \quad \delta_N^* = \frac{\delta_N \bar{\phi}}{\gamma_T}, \quad \delta_i^* = \frac{\delta_i}{\gamma_T}, \quad \gamma_A^* = \frac{\gamma_A \varepsilon \bar{\phi}}{\gamma_T},$$

$$\gamma_C^* = \frac{\gamma_C \gamma_A \bar{\phi}^2}{\gamma_T^2}, \quad k_A^* = \frac{k_A \delta_N \bar{\phi}}{k_E \gamma_T}, \quad k_N^* = \frac{k_N \bar{\phi}}{k_E},$$

$$k_C^* = \frac{k_C \delta_N \bar{\phi}}{k_E \gamma_T}, \quad \alpha^* = \frac{w_D}{w_T}, \quad \beta^* = \frac{\beta \bar{\phi}}{\varepsilon},$$

$$w_C^* = \frac{w_C \delta_N \gamma_A \bar{\phi}^2}{k_E \gamma_T^2}, \quad w_T^* = \frac{w_T \delta_N \bar{\phi}^2}{k_E \gamma_T},$$

$$\tilde{u}_N^* = \frac{\bar{\phi} \tilde{u}_N}{\varepsilon}, \quad \bar{u}_N^* = \frac{\bar{\phi} \bar{u}_N}{\varepsilon}, \quad t^* = \gamma_T t,$$

where $i = A, C, D, T$.

The formation of a necrotic core and a boundary layer of coexisting living and dead tumor cells is evident in Fig. 6 (in Fig. 6a the lines corresponding to the nutrient density and live cell density overlap).

Tumor cells produce TAF that diffuses in the environment. At the stage represented in Fig. 6a endothelial cells (the thick horizontal segment to the left and the right of the tumor) have been barely stimulated and the nutrient reaching the tumor is only the one diffusing through the environment.

As the pre-existing capillary network is reached, new capillary sprouts are formed starting from the pre-existing network and rapidly tending toward the tumor surface (Fig. 6b), where they duplicate even further for the presence of more TAF (Fig. 6c). This brings more nutrient, so that the layer of living cells thickens and the tumor growth accelerates (this can be noticed by comparing the locations of the tumor surface.)

It can be noticed that some capillary sprouts penetrate the tumor, or more precisely, the tumor grows and includes them. Eventually, the tumor reaches the pre-existing network and grows over it (Fig. 7b). In this last figure the amount of nutrient at the surface is about 2.5 and is not shown in the graph.

In Figs. 8 and 9 the simulation is developed having in mind possible medical actions and aims at focusing on what happens when angiostatins are injected so that the endothelial cells are no longer sensitive to the presence of TAF and do not feel stimulated to undergo mitosis. Injection is simulated at $t^* = 28$ corresponding to Fig. 8a. In the model growth of new capillary sprouts is inhibited by putting $\gamma_C^* = 0$. This brings up a progressive death of capillaries as the endothelial cells dying of natural death are no longer replaced. This well-known process is similar to what happens in wound healing. New capillaries form because there is a stimulus of doing so, but as the wound is cured, the stimulus ceases and the new capillaries are destroyed leaving unchanged the pre-existing network they originated from.

In this case, the outer rim becomes less proliferative while more and more cells start dying. This brings

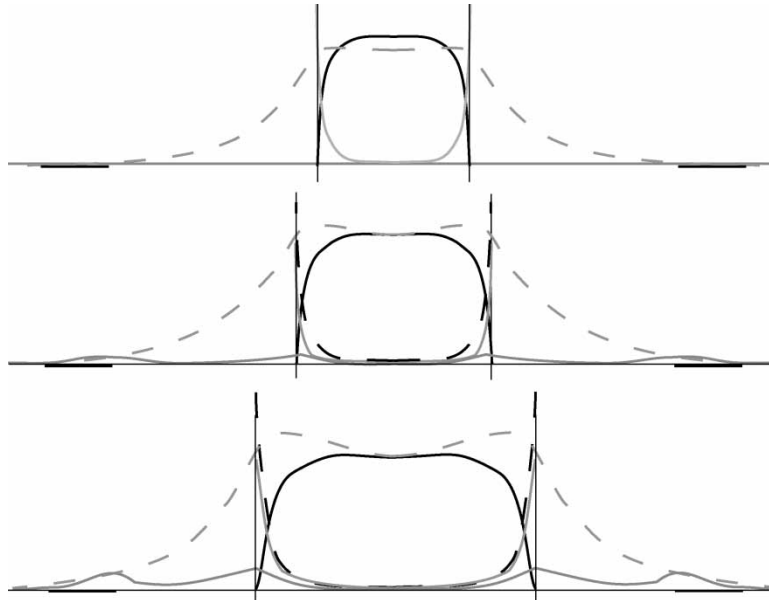

FIGURE 6 Angiogenic process. The plots present the evolution of the densities along the diameter of the tumor at $t^* = 10, 16, 22$. Full lines refer to tumor cells (black to dead and gray to live ones), the dashed line to nutrient density (black) and TAF density (gray). The dark gray line defined both inside and outside the tumor refer to the new capillaries. The location of the old capillaries is given by the short segments on the axis. The simulation uses the following values of the parameters $\delta_A^* = 0, \delta_N^* = 5, \delta_A'^* = 0.05, \delta_C^* = 0.5, \delta_D^* = 0.005, \delta_T^* = 2.5, \gamma_A^* = 1, \gamma_C^* = 7.5, k_A^* = 50, k_N^* = 1, k_C^* = 5, w_C^* = 75, w_T^* = 1000, \alpha^* = 0.5, \beta^* = 5, \tilde{u}_N^* = 0.95, \bar{u}_N^* = 0.9$.

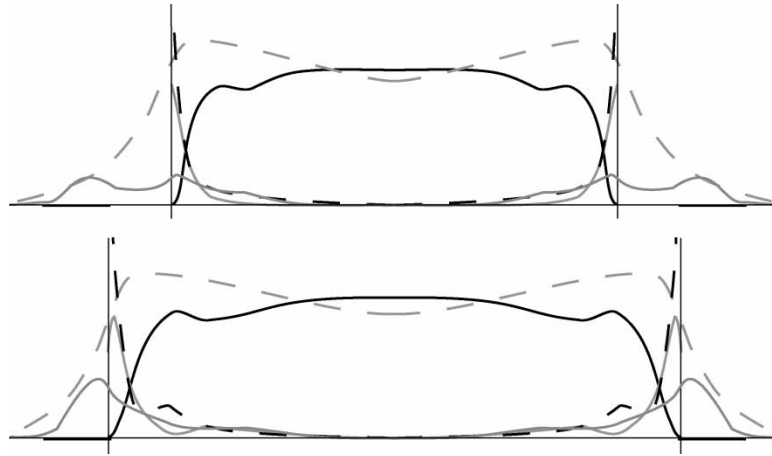

FIGURE 7 Vascularized tumor. The plots present the evolution of the previous simulation at longer times ($t^* = 28, 31$). Notation as in Fig. 6.

a rapid deceleration of tumor growth. As the necrotic core is much larger than the one present in the avascular case, at a certain point disintegration of dead cells in waste products and production of new cells in the outer rim are unbalanced causing a regression in size of the tumor (Fig. 9b). When the capillary network is destroyed, the tumor goes back to the avascular state as nutrient only diffuses through the environment. The size of the multicell spheroid will decrease on and eventually reach the limit radius characterized by the balance between proliferation in the outer rim and disintegration of dead cells.

Before concluding the section it should be mentioned that in the earliest papers using the method presented in this section, e.g. McElwain and Pettet (1993), Byrne and Chaplain (1996), the assumption of constant volume ratio for a single constituent is used together with a Darcy’s-type closure. In this case there is no relation between Σ and ϕ_T , i.e. between compression and stress, and Eq. (43) is rather a potential flow assumption on the velocity field.

In this case one can write the following equation for the “potential” Σ

$$\nabla \cdot [K(\nabla \Sigma - \phi_T \mathbf{f}_T)] + \frac{G_T}{\phi_T} - D_T = 0. \quad (46)$$

Of course, dropping the stress–compression relation has the advantage of simplifying the model, but, unfortunately, does not deal with those problems in which the stress plays an important role.

The above simulations refer to problems in one space dimensions. Various techniques have been developed for problems in more than one space dimension (see Valenciano and Chaplain, 2003; 2004), which may be technically generalized to deal with the above problems.

Porous Media Models

The last few years saw the development of a multiphase approach to describe tumor growth. These papers (Please *et al.*, 1999; Breward *et al.*, 2001; 2002; Landman and

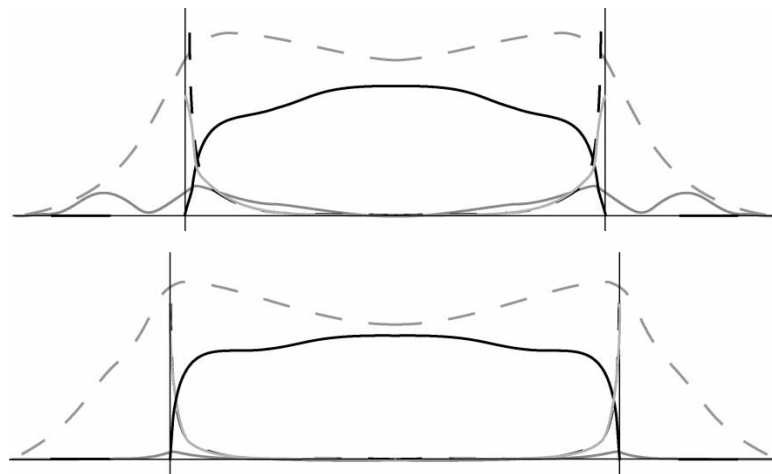

FIGURE 8 Regression of capillary network at $t^* = 30, 40$ due to the inhibition of duplication of endothelial cells. Notation as in Fig. 6.

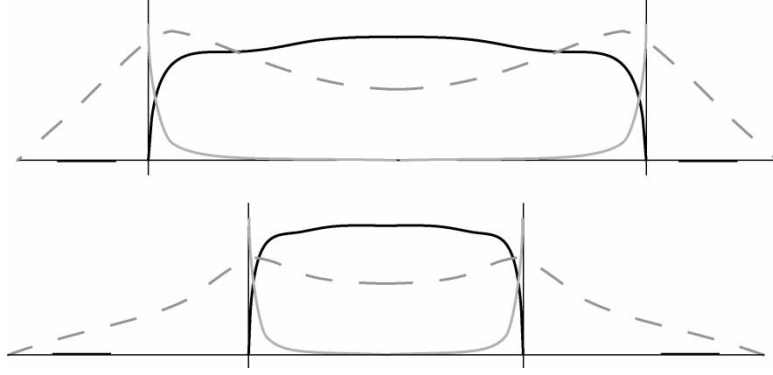

FIGURE 9 Regression of the tumor occurring at $t^* = 60, 100$ due to decrease of the amount of nutrient available after the regression of the capillary network. Notation as in Fig. 6.

Please, 2001; Ambrosi and Preziosi, 2002; Byrne *et al.*, 2003; Preziosi and Graziano, 2003; Byrne and Preziosi, 2004) considered the case of a single cell population living in an extracellular fluid with several chemicals diluted in it. In this case, one can write Eq. (21) and (27) for the tumor cells ($j = T$) and for the extracellular liquid ($j = \ell$).

If the mixture is closed, then by looking at mass and momentum balances for the whole mixture, the interface terms have to satisfy the following conditions related to global mass and momentum balance

$$\Gamma_T + \Gamma_\ell = 0, \quad (47)$$

$$\mathbf{m}_T^\sigma + \Gamma_T \mathbf{v}_T + \mathbf{m}_\ell^\sigma + \Gamma_\ell \mathbf{v}_\ell = \mathbf{0}, \quad (48)$$

which imply

$$\Gamma_\ell = -\Gamma_T, \quad (49)$$

$$\mathbf{m}_T^\sigma = -\mathbf{m}_\ell^\sigma + \Gamma_T(\mathbf{v}_\ell - \mathbf{v}_T), \quad (50)$$

The composite velocity equation then becomes

$$\nabla \cdot \mathbf{v}_c = \nabla \cdot (\phi_T \mathbf{v}_T + \phi_\ell \mathbf{v}_\ell) = 0. \quad (51)$$

Adding up the two momentum equations (27), after some algebra (see Farina and Preziosi, 2000 for more details) gives the momentum equation for the mixture composed by the multicellular spheroid and the extracellular liquid. If the densities of the constituents are equal the composite velocity is equal to the mass average velocity and the momentum equation for the mixture then simplifies to

$$\rho \left(\frac{\partial \mathbf{c}}{\partial t} + \mathbf{v}_c \cdot \nabla \mathbf{v}_c \right) = \nabla \cdot \mathbf{T}_m + \phi_T \mathbf{f}_T + \phi_\ell \mathbf{f}_\ell, \quad (52)$$

where \mathbf{T}_m is the stress tensor of the mixture.

One can then observe that as most biological tissues the ensemble of cells forming a multicell spheroid can be considered as a porous medium filled by the extracellular liquid. Therefore, the flow through a tumor can be described using Darcy's law

$$\phi_\ell (\mathbf{v}_\ell - \mathbf{v}_T) = -\frac{K}{\mu} (\nabla P - \mathbf{f}_\ell), \quad (53)$$

which can be deduced from Eq. (27) under suitable assumptions (see Bowen, 1976; Preziosi and Farina, 2001), also in the case of a growing porous material (in this case the permeability tensor includes a correction term related to growth).

Neglecting inertial terms and assuming the constitutive equation

$$\mathbf{T}_m = -[P + \Sigma(\phi_T)]\mathbf{I}, \quad (54)$$

with Σ positive in compression the momentum equations for the mixture writes

$$\nabla P = -\Sigma'(\phi_T) \nabla \phi_T + \phi_T \mathbf{f}_T + \phi_\ell \mathbf{f}_\ell, \quad (55)$$

where $\Sigma' = d\Sigma/d\phi_T$.

On the other hand, from Eqs. (52) and (55) one has

$$\begin{aligned} \mathbf{v}_\ell &= \mathbf{v}_T - \frac{K}{\mu(1 - \phi_T)} (\nabla P - \mathbf{f}_\ell) \\ &= \mathbf{v}_T + \frac{K}{\mu(1 - \phi_T)} [\Sigma'(\phi_T) \nabla \phi_T + \phi_T (\mathbf{f}_\ell - \mathbf{f}_T)], \end{aligned} \quad (56)$$

which can be substituted back in Eq. (51) to give

$$\nabla \cdot \left\{ \mathbf{v}_T + \frac{K}{\mu} [\Sigma'(\phi_T) \nabla \phi_T + \phi_T (\mathbf{f}_\ell - \mathbf{f}_T)] \right\} = 0. \quad (57)$$

The model for a multicell spheroid as a growing poroelastic medium can then be written as follows

$$\begin{aligned} \frac{\partial \phi_T}{\partial t} + \nabla \cdot (\phi_T \mathbf{v}_T) &= \frac{\Gamma_T}{\rho}, \\ \nabla \cdot \mathbf{v}_T + \nabla \cdot \left\{ \frac{K(\phi_T)}{\mu} [\Sigma'(\phi_T) \nabla \phi_T + \phi_T (\mathbf{f}_\ell - \mathbf{f}_T)] \right\} &= 0, \\ \nabla P &= -\Sigma'(\phi_T) \nabla \phi_T + \phi_T \mathbf{f}_T + \phi_\ell \mathbf{f}_\ell, \end{aligned} \quad (58)$$

$$\frac{\partial u_i}{\partial t} + \nabla \cdot (u_i \mathbf{v}_\ell) = \nabla \cdot (Q_i \nabla u_i) + \tilde{G}_i - \tilde{D}_i u_i$$

It is important to remark at this point that in the one-dimensional case Eq. (51) can be considerably simplified as

it can be integrated to give (in the Cartesian case)

$$\phi_T v_T + (1 - \phi_T) v_\ell = \text{C.st.} \quad (59)$$

For symmetry reasons in the center of the tumor both liquid and cell velocity vanish, so the integration constant is zero. This allows one to explicitly write

$$v_\ell = -\frac{\phi_T}{1 - \phi_T} v_T, \quad (60)$$

which can be substituted back in the modified Darcy's law (53) to get (neglecting body forces)

$$v_T = \frac{K}{\mu} \frac{\partial P}{\partial x}, \quad (61)$$

or

$$v_T = -\frac{K}{\mu} \frac{\partial \Sigma}{\partial x}. \quad (62)$$

Thus, extracellular liquid and tumor cells move in opposite directions, the former down the liquid pressure gradient (and up the stress gradients), the latter up the liquid pressure gradients (and down the stress gradients).

However, we remark that this reasoning cannot be generalized to the three-dimensional case, because Eq. (55) does not imply the vector version of Eq. (62) which is, then, an assumption that can and need be justified on a different theoretical basis, as explained in the "1D problems for constrained mixtures" section.

The poroelastic biphasic model (58) is certainly the simplest among all conceivable multiphase models and can be developed along several directions, for instance, including more populations. Some initial tri-phasic models have been developed considering the extracellular matrix either assuming that it is stiff (Ambrosi and Preziosi, 2002; Preziosi and Graziano, 2003), or allowing some deformability to the extracellular matrix in one-dimensional problems (Jackson and Byrne, 2000). Finally, in Breward *et al.* (2003) tumor cells, extracellular material and blood vessels are considered, assuming that the pressure of the blood vessel is known.

As an example we will briefly consider one of the models proposed in Ambrosi and Preziosi (2002) to model the tumor and the extracellular matrix as a deformable porous material permeated by the extracellular liquid in which nutrients with concentration u_N promote growth and stress inhibits it. The extracellular matrix is rigid keeping a constant volume ratio ϕ_e .

The model writes as

$$\begin{aligned} \frac{\partial \phi_T}{\partial t} &= \nabla \cdot [K_T(1 - \phi_e)\phi_T \nabla P + K_T \phi_T \Sigma'_T \nabla \phi_T] + \frac{\Gamma_T}{\rho}, \\ \nabla \cdot \left[\left(K_T(1 - \phi_e)^2 + \frac{K_\ell}{\mu_\ell} \right) \nabla P \right. \\ &\quad \left. + K_T(1 - \phi_e)\Sigma'_T \nabla \phi_T \right] = 0 \end{aligned} \quad (63)$$

together with the diffusion equation for the nutrients.

More specifically, the following hypothesis are used for the functions Σ_T and Γ_T

1. Cells in regions with a very low volume ratio $\phi_T < \phi_0$ experience no forces from the other cells.
2. Cells in regions with a high volume ratio $\phi_T > \bar{\phi}$ experience a repulsive force growing to infinity when ϕ_T tends to ϕ_M .
3. For intermediate values of the volume ratio cells experience an attractive force which balances the repulsive forces when $\phi_T = \bar{\phi}$.
4. Proliferation occurs if the nutrient concentration exceeds the threshold value \bar{u}_N .
5. Cell proliferation is strongly affected by the presence of other cells which exert stress on the membrane of the replicating cell. In particular, the proliferation rate approaches zero as the stress grows.

A stress–volume ratio relation with the characteristics 1–3 is

$$\Sigma(\phi_T) = \Sigma_0 \frac{(\phi_T - \phi_0)_+^\alpha (\phi_T - \bar{\phi})}{(\phi_M - \phi_T)^\beta} \quad (64)$$

where $\phi_0 < \bar{\phi} < \phi_M$, while the following growth term is considered satisfies the conditions 4 and 5

$$\frac{\Gamma_T}{\rho} = \frac{\gamma \phi_T}{1 + \sigma \Sigma(\phi_T)} (u_N - \bar{u}_N)_+ - \delta_T \phi_T, \quad (65)$$

where the first term represents the rate of cell proliferation and the second one the rate of apoptosis.

The boundary condition for the volume ratio is obtained through a condition imposed on the stress acting on the multicellular spheroid. If a stress $\Sigma_{\text{ext}} > 0$ is applied to the tumor, the corresponding volume ratio will be $\phi_{\text{ext}} = \Sigma^{-1}(\Sigma_{\text{ext}})$. In the stress-free case, $\phi_T = \bar{\phi}$.

The dimensionless form of the free-boundary problem related to Eq. (63) (the boundary moves with the velocity of tumor cells) depends on the following dimensionless groups

$$\begin{aligned} D^* &= \frac{K_T \Sigma_0}{Q}, \quad \gamma^* = \frac{\gamma n_{\text{ext}}}{\delta_N}, \quad \delta^* = \frac{\delta_T}{\delta_N}, \\ \sigma^* &= \sigma \Sigma_0, \quad \bar{u}_N^* = \frac{\bar{u}_N}{n_{\text{ext}}}, \quad K^* = \frac{K}{\mu_\ell K_T}. \end{aligned} \quad (66)$$

It can be noted that in practice $\gamma^*, \delta^* \ll D^* \ll 1$ and $K^* \ll 1$. Therefore, diffusion dominates convection as a transport mechanism for the nutrient. On the other hand, cell duplication/apoptosis is a much slower process than cell motion.

Three phases of growth can be recognized during the evolution. In Fig. 10a, the tumor is still small. All cells duplicate because the level of nutrient is everywhere larger than u_N . The maximum value of the volume ratio, and therefore of the stress, is in the center of the tumor (clearer region). Tumor cells move from the center

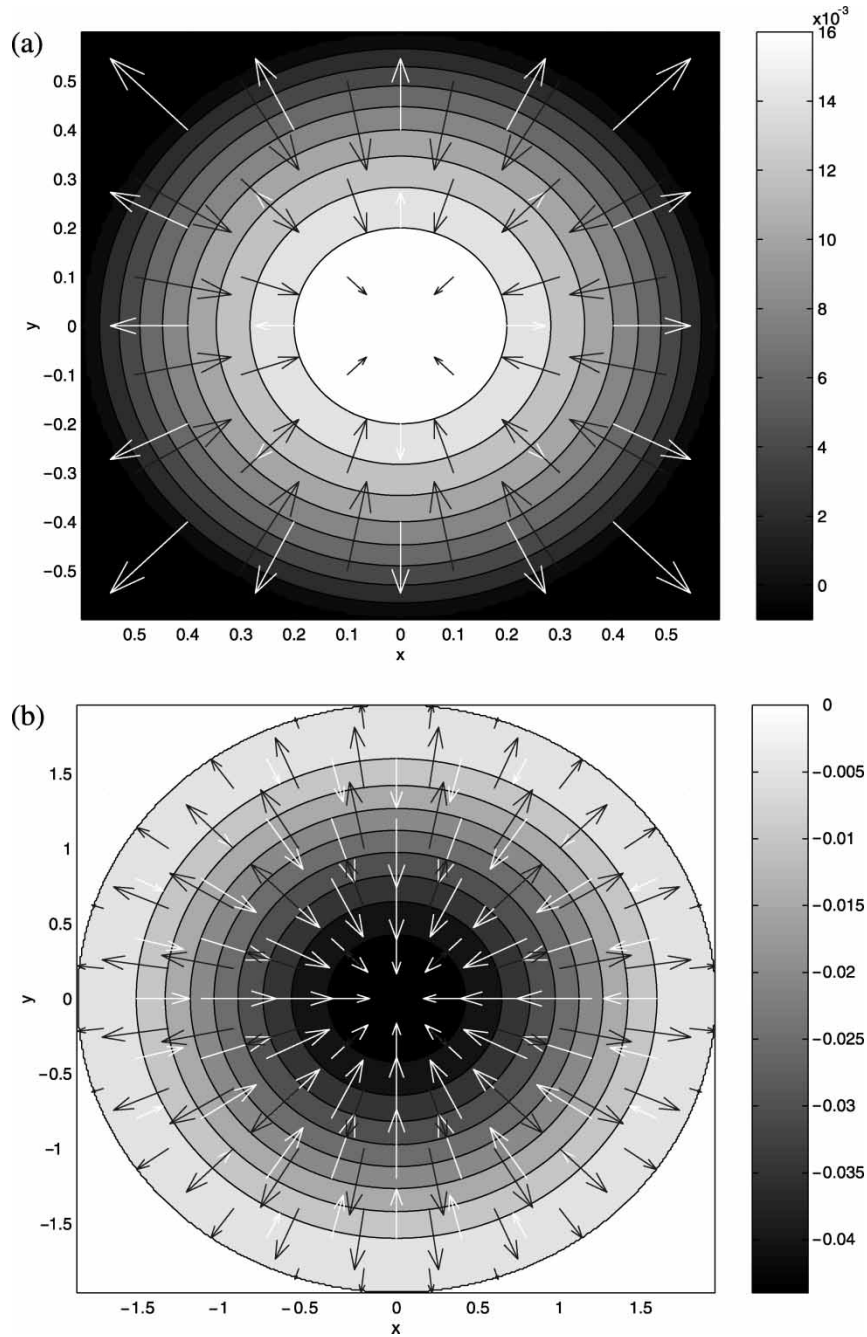

FIGURE 10 Volume ratio of a multicell spheroid, extracellular liquid velocity (darker arrows) and tumor cell velocity (lighter arrows) at $t^* = 500$ (a) and at the stationary configuration (b). Darker regions correspond to lower volume ratios, lighter regions to higher volume ratios. The initial dimensionless radius of the tumor is 0.1 and the value of the parameters are $D^* = \kappa = 0.1$, $\gamma^* = 0.01$, $\delta^* = 0.001$, $\sigma^* = 0$, $u_v^* = 0.5$, $\alpha = 2$, $\beta = 1/2$, $\phi_0 = 1/3$, $\bar{\phi} = 0.8$, $\phi_M = 1$. The scales on the right of the plots refer to the difference $\phi_T - \bar{\phi}$.

to the border of the tumor, while the liquid moves toward the center.

As the tumor grows the maximum compression moves from the center toward the border. The tumor can then be divided into three regions:

- a central one where the volume ratio of tumor cells is below the stress-free value $\bar{\phi}$ with a minimum in the center;
- an intermediate region where the volume ratio of tumor

cells is above the stress-free value and increases till it reaches a maximum;

- a border region in which the volume ratio of tumor cells decreases.

In the first two regions tumor cells move towards the center, while in the third one they move toward the boundary, pushing forward the border of the tumor. The velocity of the fluid and of the cells vanishes where the volume ratio reaches its maximum. The last two regions can be identified

with the proliferating region characterized by cells moving away from the point of maximum and organic liquid sucked in.

In the stationary configuration the maximum volume ratio is achieved at the border, which does not move any more (Fig. 10b). Tumor cells, which are created in the outer region, move towards the center where they do not find enough nutrient and die. On the other hand, the organic liquid moves toward the border where it is used by the growing cells. This is in agreement with the phenomenon of internalization of cells described in Dorie *et al.* (1982; 1986).

Figure 11 shows how the stationary dimension of the tumor decreases as the load Σ_{ext} applied to the border increases. For $\sigma^* = 0$ the radius of the tumor moderately decreases due to mechanical compression. For higher values of σ^* the decrease is much more pronounced because of the decreased proliferation in Eq. (65) and there is a threshold value of the applied load above which the tumor disappears because of the applied load. From the application viewpoint, this suggests that if there were a method to make tumor cells more sensible to mechanical compression, e.g. making its mitotic or apoptotic rate depend on the stress, this could be used to control the size of the tumor. Therefore, the models in Ambrosi and Preziosi (2002) and Byrne and Preziosi (2004) show the existence of a stress-related limit radius in addition to the well-known limit radius related to the availability of nutrient.

An aspect to recall is that when growing in an organic tissue the stress acting on the tumor is due to the compression of the external tissue. Therefore, the limit tumor dimension depends on the tissue the tumor is growing into, the ability of the tumor to degrade it and the ability of the external tissue to stand stress and replace degraded cells.

THERAPEUTICAL ACTIONS

An interesting field of application of mathematics to medicine is the modeling of therapeutical actions related both to specific models of tumor dynamics in its interaction with the immune system and to specific models related to the tumor progression.

A large variety of therapeutical actions are known in the field of medicine. A brief account is given in this review with reference to three specific actions:

- Modeling of the actions applied by proteins to activate the immune defense (Forni *et al.*, 2001; Lollini and Forni, 2002), thus preventing the ability of tumor cells to inhibit immune cells;
- Control of angiogenesis phenomena, that is the formation of new blood vessels from pre-existing vasculature (Folkman, 2001; Folkman and Kerbel, 2002) thus preventing tumor growth by limiting the feeding ability from blood vessels.

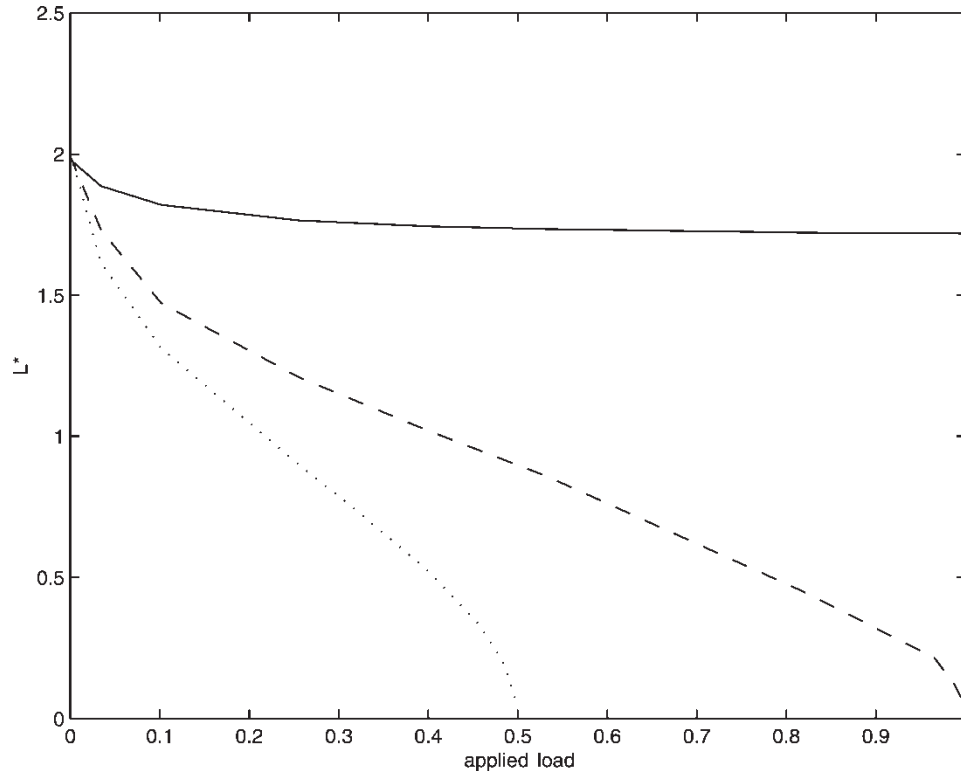

FIGURE 11 Equilibrium size of the tumor $L^* = \left(\sqrt{\delta_N/K}\right)L$ as a function of the external load Σ_{ext}^* for $\gamma^* = 0.01$, $\delta^* = 0.001$ and $\sigma^* = 0$ (full), $\sigma^* = 4$ (dashed) and $\sigma^* = 8$ (dotted).

- Drug transport and diffusion through the tumor interstitium.

The “Phenomenological description of therapeutical actions” section will provide an overview on the phenomenology of these therapeutical actions, while the “Modeling therapeutical actions: kinetic framework” and “Modeling therapeutical actions: macroscopic framework” sections will refer mainly to the mathematical modeling.

Phenomenological Description of Therapeutical Actions

There is experimental evidence that immunotherapy has the potential to treat many tumor types (Dredge *et al.*, 2002). Immunotherapy may include both active mechanisms and passive mechanisms (adoptive cancer immunotherapy) because both of them have the ability to treat different tumor types. The immunotherapy approach involves the activation of specific tumor antigen combined with incorporation of an immunological adjuvant into a vaccine regime. In detail, cancer vaccines involve the induction of an active immune response that may lead to the subsequent destruction of tumor tissue. On the other hand, as reported in Nani and Freedman (2000), an adoptive cancer immunotherapy involves the use of tumor-killing lymphocytes and lymphokines engaging in a search and destroy anti-cancer activity. Various types of adjuvant are used, for example cellular components to proteins and cytokines. Following Forni *et al.* (2001), tumor vaccine and cytokine therapy are two methods of promoting an anticancer immune response and these techniques are highly effective when combined. In cancer prevention using cancer vaccines the target is not the tumor mass but the potential risk of cancer (the so-called primary prevention), a preneoplastic lesion (the so-called secondary prevention) or a small number of isolated neoplastic cells remaining after a temporarily successful therapeutical treatment (the tertiary prevention). Moreover, vaccination after the removal of a tumor mass can stop the formation of minimal residual disease or metastatic diffusion. The central problem of this therapeutical approach is to find an equilibrium between tumor prevention efficacy and the risk of inducing autoimmunity associated with the vaccine administration. The importance of the risk increases in patients with advanced cancer with respect to the case of preneoplastic disease. The state of the art at the moment is that the experimental data related to experiments with mouse models suggest that using vaccines to prevent tumor is a plausible prospect and vaccination can be considered as an effective new prospect in the prevention of carcinogenesis and the inhibition of established preneoplastic lesions.

Referring to the second therapy, e.g. the control of angiogenesis phenomena, tumor progression and growth cannot occur without angiogenesis, which supplies the necessary oxygen and nutrients to the growing tumor.

As described in Kalluri (2003), blood vessels are composed by basement membrane, pericytes and vascular endothelial cells. As reported in Fahmi *et al.* (2003), angiogenesis is a multistep process involving degradation of endothelial basement membrane (a specialized form of extracellular matrix also known as the basal lamina), endothelial cell migration, proliferation, canalization, branching and maturation of neovessels. Endothelial cells usually have an average turnover time of 100 days and are the most quiescent and genetically stable cells of the body, while, for example, the bone marrow cells show a turnover time of 5 days. However, during angiogenesis, the vascular endothelial cells proliferate as rapidly as bone marrow cells. This increase in proliferation is associated with degradation of the basement membrane, which starts to sprout pre-existing microvessels invading the extracellular matrix. The vessels are now able to form tubes and loops capable of conducting blood flow. Following Folkman and Kerbel (2002) and Benjamin and Bergers (2003), cancer cells begin to promote the so-called “angiogenic switch” early in tumorigenesis.

Various angiogenesis inhibitors have been developed to target endothelial cells and stop the process. Still referring to Folkman and Kerbel (2002), a new class of drugs is represented by two type of angiogenic inhibitors, direct and indirect, and they are extremely important in cases for which the general rules involving conventional chemotherapy might not apply. Direct angiogenesis inhibitors (angiostatin and others) prevent vascular endothelial cells from proliferating and migrating, while indirect angiogenesis inhibitors can prevent the expression of the activity of one of the tumor proteins which drive the angiogenic switch. Another feature of the angiogenesis process is the evident abnormal vasculature as a hallmark of a solid tumor (Jain, 2003). Tumor vessels are organized in a chaotic fashion and show a pattern very different from the normal vascular networks. As described earlier, the normalization of this abnormal vasculature can facilitate drug delivery to tumors and it represents another important goal in the antiangiogenic therapy.

Referring to the third therapy, e.g. the drug transport and diffusion through the tumor interstitium, this is the first step of any chemotherapeutical action. After perfusion the drug has to diffuse in the tissue and reach the tumor. Thus, one of the most important issues in modeling cancer therapies is to understand the transport mechanisms in the tumor interstitium as it has important implications in the development of strategies to improve drug penetration in tumor masses.

It is clear that, since the selective tumor cell kill depends on the concentration-time history of a drug, an accurate modeling of the evolution of drug concentration in the interstitial space of a tumor would be extremely useful in developing optimal dose schedules of anticancer agents.

Both convection and diffusion in the tumor mass are influenced by the size of the molecules forming the mass, which varies considerably. While low-molecular-weight drugs move almost freely in the extracellular space,

high-molecular-weight drugs have more difficulties both in perfusing through the capillary walls and in diffusing in the porous structure of the tumor. Of course, the success of the use of a macromolecule depends on how well it penetrates the tumor and therefore understanding the transport mechanisms in a tumor is becoming more and more important as nowadays a wide range of therapies use high-molecular-weight agents such as proteins, monoclonal antibodies, gene vectors, viruses, liposomes or even engineered macrophages. It is then clear how an appropriate mathematical modeling of the physicochemical processes involved in drug diffusion may be helpful in proposing and designing novel strategies to improve the delivery of macromolecular agents to solid tumors.

In normal tissues, the dominant mechanism of transport for large molecules is convection due to fluid flow driven by interstitial fluid pressure gradients from the vascular to the lymphatic system. However, most tumors do not have anatomically well-defined lymphatic vessels, which reduces interstitial fluid flow. Then diffusion becomes the relevant mechanism of transport for macromolecules. On the other hand, the vascular system is sometimes leaky, which favors the extravasation of bigger drugs. The combination of reduced interstitial fluid flow and the slow diffusion rate of macromolecules in the tumor interstitium are possible causes of the therapeutic inefficiency of large molecular drugs (see for instance, the works of Jain, 1987a,b; 1994; 1996).

The sections below will be devoted to a review of the mathematical models describing the main features of each of the three therapeutical actions described above. One of the main reasons for working at a theoretical level in this context is to obtain instruments (the mathematical models and their outputs) able to help in planning the future research.

Modeling Therapeutical Actions: Kinetic Framework

Methods of mathematical kinetic theory described in the “Modeling by generalized kinetic cellular theory” section can be applied to model both the actions undertaken by proteins to activate the immune defense, and the control of angiogenesis in contrasting the growth of tumor cells by preventing the feeding actions of endothelial cells.

The research activity in this field is only at a preliminary stage. Referring to De Angelis and Jabin (2004), the general idea involves including the therapeutical actions in the framework stated in De Angelis and Mesin (2001) and De Angelis and Jabin (2003). Therapeutical actions are described by distribution functions over the variable related to the microscopic internal state of the individuals. The biological state has the general meaning of therapeutical ability for the particles of the therapeutical host and it needs to be specialized with reference to the specific medical action which is modeled. In the cases which have been considered, it can be either the control of the activation ability of the immune system, or the control of the feeding ability of the environmental cells.

The model consists of an integro-differential system of evolution equations over time and the biological state of the cells, for all the first distribution functions related to each population.

The initial value problem can be posed, and an asymptotic analysis carried out, showing that the evolution of the system may end up either with the blow-up of the host or with the suppression of the host, depending on the initial conditions and on the parameters of the system. It can also be proved that, assuming suitable initial conditions for each of the therapies, it is always possible to have the suppression of the tumor, and this result is independent of the presence of the other therapy. Of course, this is a pure mathematical result which unfortunately does not always correspond to realistic conditions of a therapeutical procedure.

Modeling Therapeutical Actions: Macroscopic Framework

Most of the papers dealing with macroscopic models of cancer therapies focused either on anti-angiogenic strategies or on the drug transport to the tumor.

In the “1D problems for constrained mixtures” and “One constituent on a rigid substratum and Darcy’s-type closure” sections, we already presented two models dealing with therapeutical actions. In particular, the model by De Angelis and Preziosi (2000) depicted the action of a generic anti-angiogenic drug with the regression of the capillary network and then of the tumor (Figs. 6–9). Other papers dealing with the effect of anti-angiogenic drugs are those by Orme and Chaplain (1997), Jackson and Byrne (2000), Levine *et al.* (2001), Jackson (2002) and Planck and Sleeman (2003). Actually the last three papers also develop in a multiscale framework, keeping in mind the need of passing from a microscopic description to a macroscopic one through random walk techniques or, vice versa, through discretization procedures, which are better suited for a cellular description.

It is interesting to observe that the importance of using mathematical models to simulate the action of a drug is also understood by research groups in medicine, like Hahnfeldt *et al.* (1999), who used a simplified model to optimize the schedule of a specific antiangiogenic drugs (angiostatin, endostatin and TNP470).

Chaplain and Anderson (2003) instead used a discretization procedure of a macroscopic model to build a vascular tree and then examined the flow of a generic drug in the vascular tree. In particular, they focused on the dependence of the quantity of drug reaching the tumor from the type of vasculature and the type of tumor that stimulated angiogenesis. On the other hand the model presented at the end of the “1D problems for constrained mixtures” section (Bertuzzi *et al.*, 2003) more closely referred to the effect of a drug perfusing through a capillary on a tumor cord surrounding the capillary.

As explained by Netti and Jain (2003), there are two interlaced aspects one has to be aware of in modeling this

process: the influence of the size of the drug and the mechanisms driving the transport and the diffusion of the drug. Besides the capillary-lymphatic exchange, interstitial fluid flow is influenced by tissue deformation. In fact, as already discussed in the “Porous media models” section, tumors can be modeled as poroelastic materials which are deformable so that fluid flow couples with the mechanics of the tissue. The effect of this coupling on drug delivery has been studied by Boucher and Jain (1992) and Netti *et al.* (1995; 1997; 2000).

Form the point of view of modeling Owen and Sherratt (1998; 1999) studied the penetration of macrophages toward the hypoxic regions of tumors. They assumed that their motion was mainly due to free diffusion and then their model consists of a system of reaction–diffusion equations. In particular, they show how the presence of macrophages can induce heterogeneities and spatial patterning within growing tumors. Finally, Ward and King (2003), working on the framework described in the “1D problems for constrained mixtures” section, investigated the effects of penetration of a small drug in a multicell spheroid.

ON THE INTERACTIONS BETWEEN MATHEMATICS AND BIOLOGY AND PERSPECTIVES

The critical analysis proposed in this section rather than being related to general topics will be focused on the analysis of the contribute that an interdisciplinary approach can give to the development of a mathematical theory for biological systems. Certainly the above perspective is one of the most fascinating and challenging targets of the research activity which will be developed in this century. The scientific community appears convinced that a great deal of research efforts will be devoted to this target.

The reasoning starts from the idea that a mathematical description is effective if related to the observation scale which is needed for the correct interpretation of a certain biological system based not only on experiments, but also on a theoretical approach. Theoretical biology is essentially founded on theories developed at the cellular and subcellular scale, even when the system shows macroscopic phenomena.

Referring specifically to the system we are dealing with, the onset is related to DNA corruption which modify various cellular activities. Later cells condense into a solid form which interacts with the outer environment by means of various carriers: chemical factors, blood capillary sprouts, and so on. However, even in this macroscopic aggregation, the overall evolution is organized by events at the microscopic scale.

Doubtfully, mathematical models related to gross quantities are useful to biological theories. A large variety of this type of models have been proposed generally stated in terms of ordinary differential equations. The main

drawback of these models is that their parameters are related to gross phenomena rather than to cellular properties. This is also occasionally the case of some models with space structure stated in terms of partial differential equations.

Going on with this reasoning, one can state that the variables of the model should be related to well-defined biological functions and that cell interactions should be ruled by subcellular properties. This feature should be preserved even when macroscopic phenomena appear and the equations of continuum mechanics may be useful or even necessary. Hence, the parameters of these models should still be related to biological functions.

It is worth, also from the view point of applied mathematicians, investigating on the analogy between mechanics of classical particles and dynamics of interacting cells. The relevant difference is that particles interact according to laws of classical mechanics. The mathematical description of the interaction is delivered to models of force potentials based on specific properties (at the lower scale) of the particles. Making the distance between particles zero, in the framework of suitable asymptotic limits, yields the derivation of macroscopic equations from the microscopic ones.

The above methodological approach can be followed, at least in principle, for multicellular systems. As announced in the “Modeling by generalized kinetic cellular theory” section, some preliminary results have already been obtained. The development of a statistical mechanics theory has been developed in various recent papers as documented in the paper by Bellomo *et al.* (2004), while the asymptotic theory proposed by Bellomo and Bellouquid (2004) shows how macroscopic evolution equations can be obtained by the microscopic description. The structure of the equations depends on scaling and rates of different biological processes at the cellular scale. The obtained equations should be referred to those obtained by the continuum mechanics approach documented in various papers (e.g. Ambrosi and Preziosi, 2002; Humphrey and Rajagopal, 2002). The mathematical literature on biological flows is documented in the paper by Kamm (2002) and Bellomo *et al.* (2003b).

As we shall see, each step needs a strategy to reduce the high complexity of the system we are dealing with without losing, however, the ability of the mathematical description to capture the essential inner features of the system.

It is interesting observing that the contents of each of the steps which will be described below can be related to some sentences of an interesting paper by Hartwell *et al.* (1999), which identifies a variety of perspective ideas offered to applied mathematicians as research targets.

Step 1. Selection of the cell populations which play the game. The difficulty involves the identification of a limited number of populations (without losing descriptive ability) out of the enormous variety of cell populations involved in the immune competition (Delves and Roitt, 2000). Referring to the biological system, one has to deal

with endothelial, immune and progressing cells. This means that each population represents a certain collective behavior of various populations with somehow analogous behavior.

Biological systems are very different from the physical or chemical systems analyzed by statistical mechanics or hydrodynamics. Statistical mechanics typically deals with systems containing many copies of a few interacting components, whereas cells contain from millions to a few copies of each of thousands of different components, each with very specific interactions. (Hartwell *et al.*, 1999).

Step 2. Modeling microscopic interactions of cells which play the game. This paper has essentially described mean-field interactions somehow analogous to Vlasov type models in mathematical kinetic theory. As already mentioned, models can be based also on short-range interactions somehow analogous to those of the classical Boltzmann equation (Cercignani, 1998). Possibly both types of interactions may occur. Interactions modify the biological functions and may generate proliferation and/or destruction processes. The modeling should take into account all above phenomena. The high complexity problem consists, as we have seen, in dealing with mechanical and biological variables and with the related interactions.

Although living systems obey the laws of physics and chemistry, the notion of function or purpose differentiate biology from other natural sciences.

In addition, the components of physical systems are often simple entities, whereas in biology each of the components is often a microscopic device in itself, able to transduce energy and work far from equilibrium. More important, what really distinguish biology from physics are survival and reproduction, and the concomitant notion of function. (Hartwell *et al.* 1999).

Step 3. Once microscopic interactions have been properly described, then the corresponding evolution equations can be derived on the basis of classical methods of the mathematical kinetic theory. An account of this type of calculations is given in the “Modeling by generalized kinetic cellular theory” section. One obtains a system of integro-differential equations with quadratic type non-linearity. The qualitative and computational analysis of the above evolution system may point out the role of all parameters on the asymptotic behavior of the solutions. This analysis is preliminary to the modeling of therapeutical actions.

Step 4. An asymptotic theory should be developed to obtain macroscopic equations from the microscopic description. Then the equations have to be compared with those delivered by purely phenomenological approach.

Step 5. A qualitative and computational analysis of the macroscopic may point out, as in Step 3, the role of all parameters on the asymptotic behavior of the solutions.

Step 6. Modeling therapeutical actions developing the necessary qualitative and computational analysis related to the optimization of therapeutical actions.

Unfortunately, the above project is not yet complete due to the great complexity related to the self-organization ability of the living matter. Its development still needs

a great deal of interdisciplinary work involving both biologists and applied mathematicians.

References

- Adam, J. (1996) “General aspects of modeling tumour growth and immune response”, In: Adam, J. and Bellomo, N., eds, *A Survey of Models on Tumour Immune Systems Dynamics* (Birkhäuser, Boston), pp 15–88.
- Adam, J.A. and Bellomo, N., eds. (1996) *A Survey of Models on Tumour Immune Systems Dynamics* (Birkhäuser, Boston).
- Ambrosi, D. and Mollica, F. (2002) “On the mechanics of a growing tumour”, *Int. J. Eng. Sci.* **40**, 1297–1316.
- Ambrosi, D. and Mollica, F. (2003) “Mechanical models in tumour growth”, In: Preziosi, L., ed, *Cancer Modelling and Simulation* (Chapman & Hall/CRC Press, London/Boca Raton, FL), pp 121–145.
- Ambrosi, D. and Mollica, F. (2004) “The role of stress in the growth of a multicell spheroid”, *J. Math. Biol.*, to appear.
- Ambrosi, D. and Preziosi, L. (2002) “On the closure of mass balance models for tumour growth”, *Math. Mod. Methods Appl. Sci.* **12**, 737–754.
- Ambrosi, D., Bellomo, N. and Preziosi, L. (2002) “Modeling the immune response to tumour heterogeneity and progression”, *J. Theor. Med.* **4**, 51–66.
- Arlotti, L., Gamba, A. and Lachowicz, M. (2002a) “A kinetic model of tumour/immune system cellular interactions”, *J. Theor. Med.* **4**, 39–50.
- Arlotti, L., Bellomo, N. and De Angelis, E. (2002b) “Generalized kinetic (Boltzmann) models: mathematical structures and applications”, *Math. Mod. Methods Appl. Sci.* **12**, 579–604.
- Arlotti, L., Bellomo, N., De Angelis, E. and Lachowicz, M. (2003) *Generalized Kinetic Models in Applied Sciences—Lecture Notes on Mathematical Problems* (World Scientific, London/Singapore).
- Bellomo, N. and Bellouquid, A. (2004) “From a class of kinetic models to macroscopic equations for multicellular systems in biology”, *Cont. Disc. Dyn Syst.* **4**, 59–80.
- Bellomo, N. and De Angelis, E. (1998) “Strategies of applied mathematics towards an immuno mathematical theory on tumours and immune system interactions”, *Math. Mod. Methods Appl. Sci.* **8**, 1403–1429.
- Bellomo, N. and De Angelis, E., eds. (2003) “Modeling and simulation of tumour development, treatment, and control”, *Math. Comp. Model.* **37**, 1121–1252.
- Bellomo, N. and Forni, G. (1994) “Dynamics of tumour interaction with the host immune system”, *Math. Comput. Model.* **20**, 107–122.
- Bellomo, N., Firmani, B. and Guerri, L. (1999) “Bifurcation analysis for a nonlinear system of integro-differential equations modelling tumor immune cells competition”, *Appl. Math. Lett.* **12**, 39–44.
- Bellomo, N., Bellouquid, A. and De Angelis, E. (2003a) “The modeling of the immune competition by generalized kinetic (Boltzmann) models: review and research perspectives”, *Math. Comput. Model.* **37**, 65–86.
- Bellomo, N., Mamontov, E. and Willander, M. (2003b) “The generalized kinetic modeling of multicomponent “real life” fluid by means of single distribution function”, *Math. Comput. Model.* **38**, 637–659.
- Bellomo, N., Bellouquid, A. and Delitala, M. (2004) “Mathematical topics on the modeling complex multicellular systems and tumour immune systems competition”, *Math. Mod. Methods Appl. Sci.*, to appear.
- Bellouquid, A. and Delitala, M. (2004) “Kinetic (cellular) models of cell progression and competition with the immune system”, *Z. Agnew. Math. Phys.* **55**, 1–24.
- Benjamin, L.E. and Bergers, G. (2003) “Tumorigenesis and the angiogenic switch”, *Nat. Rev. Cancer* **3**, 401–410.
- Bertsch, M., Gurtin, M.E., Hilhorst, D. and Peletier, L.A. (1985) “On interacting populations that disperse to avoid crowding: preservation and segregation”, *J. Math. Biol.* **23**, 1–13.
- Bertuzzi, A. and Gandolfi, A. (2000) “Cell kinetics in a tumour cord”, *J. Theor. Biol.* **204**, 587–599.
- Bertuzzi, A., Fasano, A., Gandolfi, A. and Marangi, D. (2002) “Cell kinetics in tumour cords studied by a model with variable cell cycle length”, *Math. Biosci.* **177–178**, 103–125.

- Bertuzzi, A., D'Onofrio, A., Fasano, A. and Gandolfi, A. (2003) "Regression and regrowth of tumour cords following single-dose anticancer treatment", *Bull. Math. Biol.* **65**, 903–931.
- Boucher, Y. and Jain, R.K. (1992) "Microvascular pressure is the principal driving force for interstitial hypertension in solid tumours: implication for vascular collapse", *Cancer Res.* **52**, 5110–5114.
- Bowen, R.M. (1976) "The theory of mixtures", In: Eringen, A.C., ed, *Continuum Physics* (Academic Press, New York), Vol. **3**.
- Breward, C.J.W., Byrne, H.M. and Lewis, C.E. (2001) "Modeling the interactions between tumour cells and a blood vessel in a microenvironment within a vascular tumour", *Eur. J. Appl. Math.* **12**, 529–556.
- Breward, C.J.W., Byrne, H.M. and Lewis, C.E. (2002) "The role of cell–cell interactions in a two-phase model for avascular tumour growth", *J. Math. Biol.* **45**, 125–152.
- Breward, C.J.W., Byrne, H.M. and Lewis, C.E. (2003) "A multiphase model describing vascular tumour growth", *Bull. Math. Biol.* **65**, 609–640.
- Bussolino, F., Arese, M., Audero, E., Giraudo, E., Marchiò, S., Mitola, S., Primo, L. and Serini, G. (2003) "Biological aspects of tumour angiogenesis", In: Preziosi, L., ed, *Cancer Modelling and Simulation* (Chapman & Hall/CRC Press, London/Boca Raton, FL), pp 1–22.
- Byrne, H.M. (2003) "Modeling avascular tumour growth", In: Preziosi, L., ed, *Cancer Modelling and Simulation* (Chapman & Hall/CRC Press, London/Boca Raton, FL), pp 75–120.
- Byrne, H.M. and Chaplain, M.A.J. (1996) "Modeling the role of cell–cell growth and development of carcinomas", *Math. Comput. Model.* **24**, 1–17.
- Byrne, H.M. and Chaplain, M.A.J. (1997) "Free boundary value problem associated with the growth and development of multicellular spheroids", *Eur. J. Appl. Math.* **8**, 639–658.
- Byrne, H.M. and Preziosi, L. (2004) "Modeling solid tumour growth using the theory of mixtures", *Math. Med. Biol.* **20**, 341–366.
- Byrne, H.M., King, J.R., McElwain, D.L.S. and Preziosi, L. (2003) "A two-phase model of solid tumour growth", *Appl. Math. Lett.* **16**, 567–573.
- Cercignani, C. (1998) *Ludwig Boltzmann the Man who Trusted Atoms* (Springer, Heidelberg).
- Chaplain, M.A.J., Ed. (2002) "Special issue on mathematical modeling and simulations of aspects of cancer growth", *J. Theor. Med.*, **4**.
- Chaplain, M.A.J. and Anderson, A.R.A. (2003) "Mathematical modeling of tissue invasion", In: Preziosi, L., ed, *Cancer Modelling and Simulation* (Chapman & Hall/CRC Press, London/Boca Raton, FL), pp 264–297.
- Chaplain, M.A.J. and Preziosi, L. (2004) "Misperception of stress as a cause of hyperplasia and dysplasia", preprint.
- De Angelis, E. and Jabin, E. (2003) "Qualitative analysis of a mean field model of tumour–immune system competition", *Math. Mod. Methods Appl. Sci.* **13**, 187–206.
- De Angelis, E. and Jabin, E. (2004) "Mathematical models of therapeutical actions related to tumour and immune system competition", preprint.
- De Angelis, E. and Mesin, L. (2001) "Mathematical frameworks and applications on tumours and immune system interactions", *Math. Mod. Methods Appl. Sci.* **11**, 1609–1630.
- De Angelis, E. and Preziosi, L. (2000) "Advection–diffusion models for solid tumours *in vivo* and related free-boundary problems", *Math. Mod. Methods Appl. Sci.* **10**, 379–408.
- De Angelis, E., Delitala, M., Marasco, A. and Romano, A. (2003) "Bifurcation analysis for a mean field modeling of tumour and immune system competition", *Math. Comput. Model.* **37**, 1131–1142.
- Delves, P.J. and Roitt, Y.M. (2000) "The immune system", *Adv. Immunol.* **343**, 37–49.
- Di Carlo, A. and Quilgotti, S. (2002) "Growth and balance", *Mech. Res. Comm.* **29**, 449–456.
- Dorie, M.J., Kallman, R.F., Rapacchietta, D.F., Van Antwerp, D. and Huang, Y.R. (1982) "Migration and internalisation of cells and polystyrene microspheres in tumour cell spheroids", *Exp. Cell Res.* **141**, 201–209.
- Dorie, M.J., Kallman, R.F. and Coyne, M.A. (1986) "Effect of cytochalasin B nocodazole on migration and internalisation of cells and microspheres in tumour cells", *Exp. Cell Res.* **166**, 370–378.
- Dredge, K., et al. (2002) "Adjuvant and the promo immunotherapy", *Cancer Immunol. Immunother.* **51**, 521–531.
- Fahmi, R.G., et al. (2003) "Transcription factor Egr-1 supports FGF-dependent angiogenesis during neovascularization and tumour growth", *Nat. Med.* **9**, 1026–1032.
- Farina, A. and Preziosi, L. (2000) "Deformable porous media and composites manufacturing", In: Markov, K. and Preziosi, L., eds, *Heterogeneous Media: Micromechanics, Modeling, Methods and Simulations* (Birkhauser, Basel).
- Folkman, J., et al. (2001) "Angiogenesis", In: Braunwald, E., ed, *Harrison's Principle of International Medicine* (McGraw-Hill, New York), pp 517–530.
- Folkman, J. and Kerbel, K. (2002) "Clinical translation of angiogenesis inhibitors", *Nat. Rev. Cancer* **2**, 727–739.
- Forni, G., et al. (2001) "Combined allogeneic tumour cell vaccination and systemic interleukin 12 prevents mammary carcinogenesis in HER-2/neu transgenic mice", *J. Exp. Med.* **194**, 1195–1206.
- Franks, S.J. and King, J.R. (2003) "Interactions between a uniformly proliferating tumour and its surrounding: uniform material properties", *Math. Med. Biol.* **20**, 47–89.
- Gatenby, R.A. and Maini, P.K. (2003) "Mathematical oncology: cancer summed up", *Nature* **421**, 321.
- Greller, L., Tobin, F. and Poste, G. (1996) "Tumour heterogeneity and progression: conceptual foundation for modeling", *Invasion Metastasis* **16**, 177–208.
- Gurtin, M.E. and McCamy, R.C. (1977) "On the diffusion of biological populations", *Math. Biosci.* **33**, 35–49.
- Hahnfeldt, P., Panigrahy, D., Folkman, J. and Hlatky, L. (1999) "Tumour development under angiogenic signaling: a dynamic theory of tumor growth, treatment response, and postvascular dormancy", *Cancer Res.* **59**, 4770–4775.
- Hartwell, H.L., Hopfield, J.J., Leibner, S. and Murray, A.W. (1999) "From molecular to modular cell biology", *Nature* **402**, c47–c52.
- Helmlinger, G., Netti, P.A., Lichtenbeld, H.C., Melder, R.J. and Jain, R.K. (1997) "Solid stress inhibits the growth of multicellular tumour spheroids", *Nat. Biotechnol.* **15**, 778–783.
- Hillen, T. (2002) "Hyperbolic models for chemosensitive movement", *Math. Mod. Methods Appl. Sci.* **12**, 953–980.
- Hillen, T. and Othmer, H. (2000) "The diffusion limit of transport equations derived from velocity jump processes", *SIAM J. Appl. Math.* **61**, 751–775.
- Humphrey, J.D. and Rajagopal, K.R. (2002) "A constrained mixture model for growth and remodeling of soft tissues", *Math. Mod. Methods Appl. Sci.* **12**, 407–430.
- Jackson, T.L. (2002) "Vascular tumour growth and treatment: consequences of polyclonality, competition and dynamic vascular support", *J. Math. Biol.* **44**, 201–226.
- Jackson, T.L. and Byrne, H.M. (2000) "A mathematical model to study the effects of drug resistance and vasculature on the response of solid tumours to chemotherapy", *Math. Biosci.* **164**, 17–38.
- Jain, R.K. (1987a) "Transport of molecules across tumour vasculature", *Cancer Metastasis Rev.* **6**, 559–594.
- Jain, R.K. (1987b) "Transport of molecules in the tumour interstitium: a review", *Cancer Res.* **47**, 3039–3051.
- Jain, R.K. (1994) "Barrier to drug delivery in solid tumours", *Sci. Am.* **271**, 58–65.
- Jain, R.K. (1996) "Delivery of molecular medicine to solid tumours", *Science* **271**, 1079–1080.
- Jain, R.K. (2003) "Molecular regulation of vessel maturation", *Nat. Med.* **9**, 685–693.
- Kalluri, R. (2003) "Basement membranes: structure, assembly and role in tumour angiogenesis", *Nat. Rev. Cancer* **3**, 422–433.
- Kamm, R. (2002) "Cellular fluid dynamics", *Annu. Rev. Fluid Mech.* **34**, 211–232.
- Kolev, M. (2003) "Mathematical modeling of the competition between tumours and immune system considering the role of the antibodies", *Math. Comput. Model.* **37**, 1143–1152.
- Lachowicz, M. (2002) "From microscopic to macroscopic description for general kinetic models", *Math. Mod. Methods Appl. Sci.* **12**, 993–1011.
- Landman, K. and Please, C.P. (2001) "Tumour dynamics and necrosis: surface tension and stability", *IMA J. Math. Appl. Med. Biol.* **18**, 131–158.
- Levine, H.A., Pamuk, S., Sleeman, B.D. and Nilsen-Hamilton, M. (2001) "A mathematical model of capillary formation and development in tumour angiogenesis: penetration into the stroma", *Bull. Math. Biol.* **63**, 801–863.
- Lollini, P.L. and Forni, G. (2002) "Antitumour vaccines: is it possible to prevent a tumour?", *Cancer Immunol. Immunother.* **51**, 409–416.

- Lustig, B. and Behrens, J. (2003) "The Wnt signaling pathway and its role in tumour development", *J. Cancer Res. Clin. Oncol.* **129**, 199–221.
- McElwain, D.L.S. and Pettet, G.J. (1993) "Cell migration in multicell spheroids: swimming against the tide", *Bull. Math. Biol.* **55**, 655–674.
- Nani, F. and Freedman, H.I. (2000) "A mathematical model of cancer treatment by immunotherapy", *Math. Biosci.* **163**, 159–199.
- Netti, P.A. and Jain, R.K. (2003) "Interstitial transport in solid tumours", In: Preziosi, L., ed., *Cancer Modelling and Simulation* (CRC Press/Chapman & Hall, Boca Raton, FL/London), pp 51–74.
- Netti, P.A., Baxter, L.T., Boucher, Y., Skalak, R. and Jain, R.K. (1995) "Time-dependent behaviour of interstitial fluid pressure in solid tumours: implication for drug delivery", *Cancer Res.* **55**, 5451–5458.
- Netti, P.A., Baxter, L.T., Boucher, Y., Skalak, R. and Jain, R.K. (1997) "Macro and microscopic fluid transport in living tissues: application to solid tumours", *AICHE J.* **43**, 818–834.
- Netti, P.A., Berk, D.A., Swartz, M.A., Grodzinsky, A.J. and Jain, R.K. (2000) "Role of extracellular matrix assembly in interstitial transport in solid tumours", *Cancer Res.* **60**, 2497–2503.
- Orme, M.E. and Chaplain, M.A. (1997) "Two-dimensional models of tumour angiogenesis and anti-angiogenesis strategies", *IMA J. Math. Appl. Med. Biol.* **14**, 189–205.
- Owen, M.R. and Sherratt, J.A. (1998) "Modeling the macrophage invasion of tumours: effects on growth and composition", *IMA J. Math. Appl. Med. Biol.* **15**, 165–185.
- Owen, M.R. and Sherratt, J.A. (1999) "Mathematical modeling of macrophage dynamics in tumours", *Math. Mod. Methods Appl. Sci.* **9**, 513–539.
- Plank, M.J. and Sleeman, B.D. (2003) "A reinforced random walk model of tumour angiogenesis and anti-angiogenic strategies", *IMA J. Math. Med. Biol.* **20**, 135–181.
- Please, C.P., Pettet, G.J. and McElwain, D.L.S. (1999) "Avascular tumour dynamics and necrosis", *Math. Mod. Methods Appl. Sci.* **9**, 569–579.
- Preziosi, L., ed. (2003) *Cancer Modelling and Simulation* (CRC Press/Chapman & Hall, Boca Raton, FL/London).
- Preziosi, L. and Farina, A. (2001) "On Darcy's law for growing porous media", *Int. J. Nonlinear Mech.* **37**, 485–491.
- Preziosi, L. and Graziano, L. (2003) "Multiphase models of tumour growth: general framework and particular cases", *Mathematical Modeling and Computer in Biology and Medicine Proceedings of the 5th Conference on the ESMTB* (Springer, Berlin), pp 622–628.
- Rajagopal, K.R. and Tao, L. (1995) *Mechanics of Mixtures* (World Scientific, Singapore).
- Rodriguez, E.K., Hoger, A. and McCulloch, A. (1994) "Stress dependent finite growth in soft elastic tissues", *J. Biomech.* **27**, 455–467.
- Taber, L. (1995) "Biomechanics of growth, remodeling and morphogenesis", *Appl. Mech. Rev.* **48**, 487–545.
- Valenciano, J. and Chaplain, M.A.J. (2003) "Computing highly accurate solutions of a tumour angiogenesis model", *Math. Mod. Methods Appl. Sci.* **13**, 747–769.
- Valenciano, J. and Chaplain, M.A.J. (2004) "An explicit subparametric spectral element method of lines applied to a tumour angiogenesis system of PDEs", *Math. Mod. Methods Appl. Sci.* **14**, 165–188.
- Ward, J.P. and King, J.R. (1997) "Mathematical modeling of avascular-tumour growth", *IMA J. Math. Appl. Med. Biol.* **14**, 39–69.
- Ward, J.P. and King, J.R. (1998) "Mathematical modeling of avascular-tumour growth II: modeling growth saturation", *IMA J. Math. Appl. Med. Biol.* **15**, 1–42.
- Ward, J.P. and King, J.R. (1999) "Mathematical modeling of the effects of mitotic inhibitors on avascular tumour growth", *J. Theor. Med.* **1**, 171–211.
- Ward, J.P. and King, J.R. (2003) "Mathematical modeling of drug transport in tumour multicell spheroids and monolayer cultures", *Math. Biosci.* **181**, 177–207.